

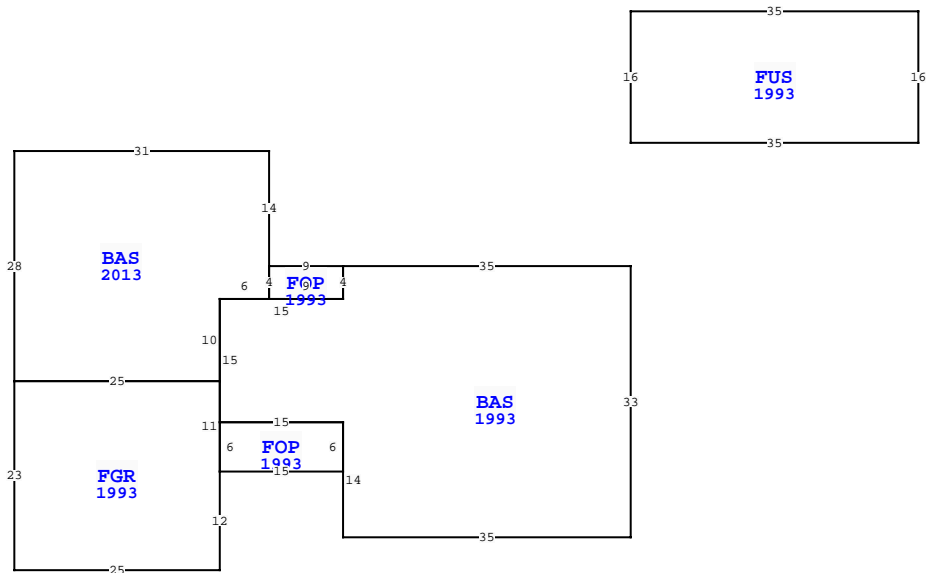

BUILDING CHARACTERISTICS		
ELEMENT	CD	CONSTRUCTION
Exterior Wall	20	FACE BRICK 60
Exterior Wall	10	ABOVE AVG 40
Roof Structure	07	GAMBREL 100
Roof Cover	12	MODULAR MT 100
Interior Wall	05	DRYWALL 100
Interior Floor	11	CLAY TILE 50
Interior Floor	13	LVT/LAMNT 50
Air Condition	03	CENTRAL 100
Heating Type	04	AIR DUCTED 100
Bedrooms	4	100
Bathrooms	3	100
Frame	02	WOOD FRAME 100
Stories	2.	2. 100
Units	0	100
BUD\$ Adjustme	06	DIST 1D 100
Occupancy	00	NONE 100
Quality	05	Quality Level 05
DOR CODE	0100	SINGLE FAMILY
MAP NUM		MKT AREA 08
NEIGHBORHOOD/LOC	8026.00	
AREA TYPE	TOTAL GROSS AREA	PCT OF BASE
BAS	1,380	100
BAS	808	100
FGR	575	55
FOP	36	30
FOP	90	30
FUS	560	100
TOTALS	3,449	

MARKET ADJUSTMENTS											
TYPE	MDL	EFF. AREA	TOT ADJ PTS	EFF. BASE RATE	REPL. COST NEW	AYB	EYB	ECON	FNCT	NORM	% COND
0100	01	3,102	118.9100	118.91	368,859	1983	1995	0	0	18.65	81.35
1 SINGLE FAM - 100% - 1989 Heated Area: 2748 HX Base Yr 1989											



NASSAU COUNTY PROPERTY		PAGE 1 of 2	6
VALUATION SUMMARY			
VALUATION BY			STANDARD
Tax Group: 6	Tax Dist:		
BUILDING MARKET VALUE			306,921
TOTAL MARKET OB/XF VALUE			58,216
TOTAL LAND VALUE - MARKET			75,600
TOTAL MARKET VALUE			440,737
SOH/AGL Deduction			217,836
ASSESSED VALUE			222,901
TOTAL EXEMPTION VALUE	HX HB		50,722
BASE TAXABLE VALUE			172,179
TOTAL JUST VALUE			440,737
NCON VALUE			0
INCOME VALUE			
PREVIOUS YEAR MKT VALUE			430,325

PERMIT NUM	DESCRIPTION	AMT	ISSUED
B1429160	SWIM POOL	28,000	08/01/2014
B1327748	ADDITION	49,043	10/01/2013
B1327497	CARPORT	14,989	07/01/2013

SALES DATA						
OFF RECORD Number	DATE	TYPE INST	Q / U	V / I	RSN CD	SALE PRICE
0552/1071	9/21/1988	WD	Q	I		115,000
GRANTOR: DANIEL JAY R						
GRANTEE: BAKER & MILEY						
0472/0288	11/01/1985	FS	U	I		100
GRANTOR:						
GRANTEE:						

EXTRA FEATURES																
L N	OB/XF CODE	DESCRIPTION	BLD CAP	L	W	UNITS	UT	Adj R	ADJ UNIT PRICE	ORIG COND	YEAR ON	YEAR ACTUAL	Q	% COND	OB/XF MKT VALUE	NOTES
1	0500	FP-PRE FAB	0	100	0	1.00	UT	3,500.00	3,500.00	100	1983	1983	3	51.5	1,803	
2	1241	WD DECK G	0	100	0	332.00	UT	11.50	11.50	100	2005	2005	3	36	1,374	
3	0810	CONCRETE A	0	100	28	672.00	SF	6.50	6.50	100	2005	2005	3	84	3,669	
4	0681	POLE SHED	0	100	5	100.00	SF	15.00	15.00	100	2005	2005	3	36	540	
5	0940	SHEDS/PORT	0	100	12	96.00	SF	20.10	20.10	100	1990	1990	3	20	386	
6	1241	WD DECK G	0	100	0	272.00	UT	11.50	11.50	100	2005	2005	3	36	1,126	
7	0861	POOL GUNIT	0	100	0	420.00	SF	85.00	85.00	100	2015	2015	3	75	26,775	
8	0855	CONC PAVR	0	100	0	851.00	SF	10.00	10.00	100	2015	2015	3	95	8,085	
9	0911	SCRN RM A	0	100	31	1,271.00	SF	17.50	17.50	100	2015	2015	3	65	14,458	
TOTALS															58,216	

BUILDING NOTES											
BLD DATE											
XF DATE											
INC DATE											
LGL DATE											
LAND DATE											
AG DATE											
05/09/2025 MLU											

BUILDING DIMENSIONS											
BAS=[YR=1993] W35 FOP=[YR=1993] W9 BAS=[YR=2013] N14 W31 S28											
FGR=[YR=1993] S23 E25 N12 FOP=[YR=1993] E15 N6 W15 S6 \$ N11											
W25\$E25 N10 E6 N4\$ S4 E9 N4\$ S4 W15 S15 E15 S14 E35 N33 \$											
PTR= N15 FUS=[YR=1993] E35N16 W35 S16 \$ S15 \$.											

LAND DESCRIPTION												TOTAL OB/XF												
L N	USE CODE	CLS	LAND USE DESCRIPTION	CAP	R D	LOC ZONE	FRONT	DEPTH	TOT LND UTS	UNIT TYPE	D T	DPH FACT	% COND	TOT ADJ	UNIT PRICE	ADJ UNIT PRICE	LAND VALUE	OTHER ADJUSTMENTS AND NOTES	YEAR	DENSITY	DECL	FRZ	YR	CONSRV
1	000100	C	RES	100	0005	OR	0.00	0.00	2.16	AC		1.00	1.00	1.00	35,000.00	35,000.00	75,600							

