

BUILDING CHARACTERISTICS		CONSTRUCTION	
ELEMENT	CD		
Exterior Wall	31	HARDIE BRD	100
Roof Structur	03	GABLE/HIP	100
Roof Cover	03	COMP SHNGL	100
Interior Wall	05	DRYWALL	100
Interior Floo	14	CARPET	60
Interior Floo	11	CLAY TILE	40
Air Condition	03	CENTRAL	100
Heating Type	04	AIR DUCTED	100
Bedrooms		4	100
Bathrooms		3	100
Frame	02	WOOD FRAME	100
Stories	1.5	1.5	100
Units		0	100
Occupancy	00	NONE	100
Quality	06	Quality Level	06
DOR CODE	0100	SINGLE FAMILY	
MAP NUM		MKT AREA	04
NEIGHBORHOOD/LOC	4035.00		
AREA TYPE	TOTAL GROSS AREA	PCT OF BASE	YEAR
BAS	1,678	100	2018
FGR	440	55	2018
FOP	94	30	2018
FSP	130	40	2018
FST	18	55	2018
FUS	347	100	2018
STR	28	10	2018
TOTALS	2,735		

MARKET ADJUSTMENTS											
TYPE	MDL	EFF. AREA	TOT ADJ PTS	EFF. BASE RATE	REPL. COST NEW	AYB	EYB	ECON	FNCT	NORM	% COND
0100	01	2,360	130.9574	130.96	309,066	2018	2018	0	0	2.50	97.50
1 SINGLE FAM - 100% - 2022 Heated Area: 2025 HX Base Yr 2022											

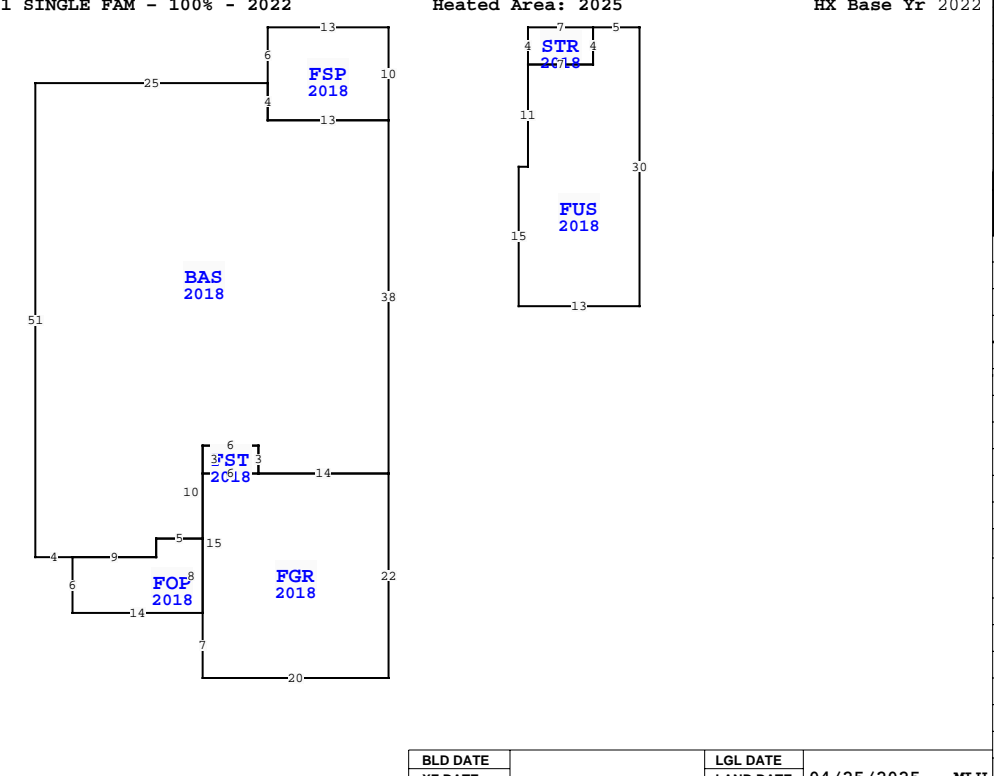

NASSAU COUNTY PROPERTY		PAGE 1 of 1	4
VALUATION SUMMARY			
VALUATION BY	STANDARD		
Tax Group: 4	Tax Dist:		
BUILDING MARKET VALUE			301,339
TOTAL MARKET OB/XF VALUE			10,999
TOTAL LAND VALUE - MARKET			85,000
TOTAL MARKET VALUE			397,338
SOH/AGL Deduction			108,755
ASSESSED VALUE			288,583
TOTAL EXEMPTION VALUE	HX HB WX		55,722
BASE TAXABLE VALUE			232,861
TOTAL JUST VALUE			397,338
NCON VALUE			0
INCOME VALUE			
PREVIOUS YEAR MKT VALUE			373,840

PERMIT NUM	DESCRIPTION	AMT	ISSUED
B1800250	CO ISSUED	0	04/04/2018
B1800250	NEW CONSTR	259,519	01/10/2018

SALES DATA						
OFF RECORD Number	DATE	TYPE INST	Q U	V I	RSN CD	SALE PRICE
2421/1259	12/29/2020	WD Q	Q	I	02	285,000
GRANTOR: GILL NICHOLAS D & KOR						
GRANTEE: LANGE TERESA J						
2191/0092	4/18/2018	WD Q	Q	I	01	231,000
GRANTOR: SEDA CONSTRUCTION COM						
GRANTEE: GILL NICHOLAS D & K						

EXTRA FEATURES																
L N	OB/XF CODE	DESCRIPTION	BLD CAP	L	W	UNITS	UT	Adj R	ADJ UNIT PRICE	ORIG COND	YEAR ON	YEAR ACTUAL	Q	% COND	OB/XF MKT VALUE	NOTES
1	0811	CONCRETE B	0	100	0	0			972.00	SF	5.20	2018	2018	3	97	4,903
2	0810	CONCRETE A	0	100	0	0			36.00	SF	6.50	2018	2018	3	97	227
3	0476	VF 6 SBPL	0	100	0	0			156.00	LF	32.00	2018	2018	3	92	4,593
4	0470	VNYL GATE	0	100	0	0			1.00	UT	300.00	2018	2018	3	92	276
5	0855	CONC PAVER	0	100	0	0			100.00	SF	10.00	2024	2023		100	1,000

BLD DATE		LGL DATE	
XF DATE	INC DATE	LAND DATE	AG DATE
		04/25/2025	MLU

BUILDING NOTES	
BUILDING DIMENSIONS	
BAS=[YR=2018;ORIG=-13,6] W25 S51 E4 E9 N2 E5 N10 E6 S3 E14 N38 W13 N4 \$	
FGR=[YR=2018;ORIG=-20,63] S7 E20 N22 W14 W6 S15 \$	
FUS=[YR=2018;ORIG=22,0] E5 S30 W13 N15 E1 N11 E7 N4 \$	
FSP=[YR=2018;ORIG=0,0] W13 S6 S4 E13 N10 \$	
FOP=[YR=2018;ORIG=-34,57] S6 E14 N8 W5 S2 W9 \$	
STR=[YR=2018;ORIG=15,0] E7 S4 W7 N4 \$	
FST=[YR=2018;ORIG=-14,48] N3 W6 S3 E6 \$	
PTR=[ORIG=0,0] E15 W15 \$	

LAND DESCRIPTION																	TOTAL OB/XF									
L N	USE CODE	CLS	LAND USE DESCRIPTION	CAP	R D	LOC ZONE	FRONT	DEPTH	TOT LND UTS	UNIT TYPE	D T	DPH FACT	% COND	TOT ADJ	UNIT PRICE	ADJ UNIT PRICE	LAND VALUE	OTHER ADJUSTMENTS AND NOTES	YEAR	DENSITY	DECL	FRZ	YR	CONSRV		
1	000100	C	RES	100		PUD	0.00	0.00	1.00	LT		1.00	1.00	1.00	85,000.00	85,000.00	85,000									