

BUILDING CHARACTERISTICS		CONSTRUCTION	
ELEMENT	CD		
Exterior Wall	31	HARDIE BRD	100
Roof Structur	04	WOOD TRUSS	100
Roof Cover	03	COMP SHNGL	100
Interior Wall	05	DRYWALL	100
Interior Floo	12	HARDWOOD	80
Interior Floo	14	CARPET	20
Air Condition	03	CENTRAL	100
Heating Type	04	AIR DUCTED	100
Bedrooms		3	100
Bathrooms		3	100
Frame	02	WOOD FRAME	100
Stories	1.	1. 100	
Units		0 100	
Quality	03	Quality Level	03
DOR CODE	0100	SINGLE FAMILY	
MAP NUM		MKT AREA	04
NEIGHBORHOOD/LOC	4014.00		
AREA TYPE	TOTAL GROSS AREA	PCT OF BASE	YEAR
BAS	2,916	100	2022
FGR	764	55	2022
FOP	228	30	2022
FOP	461	30	2022
STP	12	10	2022
UOP	24	20	2022
UOP	98	20	2022
UOP	216	20	2022
USP	784	30	2022
TOTALS	5,503		

MARKET ADJUSTMENTS											
TYPE	MDL	EFF. AREA	TOT ADJ PTS	EFF. BASE RATE	REPL. COST NEW	AYB	EYB	ECON	FNCT	NORM	% COND
0500	12	3,846	171.3600	270.75	1,041,304	2022	2022	0	0	0.50	99.50
1 SFR CUST - 100% - 2024 Heated Area: 2916 HX Base Yr 2024											

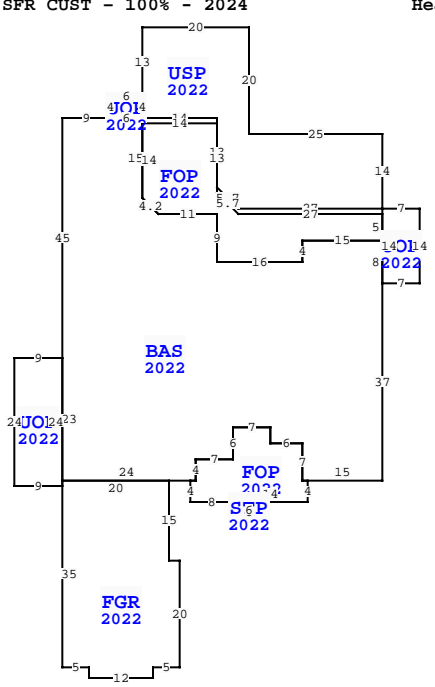

NASSAU COUNTY PROPERTY		PAGE 1 of 2	4
VALUATION SUMMARY			
VALUATION BY	STANDARD		
Tax Group: 4	Tax Dist:		
BUILDING MARKET VALUE			1,036,097
TOTAL MARKET OB/XF VALUE			105,810
TOTAL LAND VALUE - MARKET			390,000
TOTAL MARKET VALUE			1,531,907
SOH/AGL Deduction			260,422
ASSESSED VALUE			1,271,485
TOTAL EXEMPTION VALUE	HX HB		50,722
BASE TAXABLE VALUE			1,220,763
TOTAL JUST VALUE			1,531,907
NCON VALUE			24,147
INCOME VALUE			
PREVIOUS YEAR MKT VALUE			1,212,185

PERMIT NUM	DESCRIPTION	AMT	ISSUED
22003609	SCREEN ROOM	45,448	03/07/2022
21015196	SWIM POOL	70,000	11/03/2021
B2103460	NEW CONSTR	438,460	03/22/2021

SALES DATA						
OFF RECORD Number	DATE	TYPE INST	Q / U	V / I	RSN CD	SALE PRICE
2404/0666	10/28/2020	WD	Q	V	02	275,000
GRANTOR: HOSKINS WILLIAM J & I						
GRANTEE: LEWIS JASON S TRUST						
1322/0617	6/03/2005	WD	Q	V		403,800
GRANTOR: BRADY POINT PRESERVE						
GRANTEE: HOSKINS WILLIAM J &						

EXTRA FEATURES																
L N	OB/XF CODE	DESCRIPTION	BLD CAP	L	W	UNITS	UT	Adj R	ADJ UNIT PRICE	ORIG COND	YEAR ON	YEAR ACTUAL	Q	% COND	OB/XF MKT VALUE	NOTES
1	0504	FP-ELECTRI	0	100	0	0	UT	2,000.00	2,000.00	100	2022	2022	3	99	1,980	
2	0861	POOL GUNIT	0	100	0	0	SF	85.00	85.00	100	2022	2022	3	95	40,052	
3	0871	POOL HTR R	0	100	0	0	UT	2,000.00	2,000.00	100	2022	2022	3	93	1,860	
4	0855	CONC PAVER	0	100	0	0	SF	10.00	10.00	100	2022	2022	3	99	18,216	
5	0855	CONC PAVER	0	100	4	5	SF	10.00	10.00	100	2022	2022	3	99	198	
6	0810	CONCRETE A	0	100	4	4	SF	6.50	6.50	100	2022	2022	3	99	103	
7	0811	CONCRETE B	0	100	0	0	SF	5.20	5.20	100	2022	2022	3	99	8,772	
8	0462	ST/AL FNC	0	100	0	0	SF	10.00	10.00	100	2022	2022	3	95	5,244	
9	0463	FENCE GATE	0	100	0	0	UT	300.00	300.00	100	2022	2022	3	98	588	
10	0600	SUMMER KIT	0	100	0	0	UT	5,000.00	5,000.00	100	2022	2022	3	93	4,650	

BUILDING NOTES			
BLD DATE			
XF DATE			
INC DATE			
LGL DATE	03/15/2024	MLU	
LAND DATE			
AG DATE			

BUILDING DIMENSIONS											
USP=[YR=2022] W25 N20 W20 S13 UOP=[YR=2022] W6 S4											
BAS=[YR=2022] W9 S45 UOP=[YR=2022] W9 S24 E9 N24\$ S23											
FGR=[YR=2022] S35 E5 S2 E12 N2 E5 N20 W2 N15 W20\$ E24											
FOP=[YR=2022] S4 E8 STP=[YR=2022] S2 E6 N2 W6\$ E14 N4 W1 N7											
W6 N3 W7 S6 W7 S4 W1\$ E1 N4 E7 N6 E7 S3 E6 S7 E15 N37											
UOP=[YR=2022] E7 N14 W7 S14\$ N8 FOP=[YR=2022] N5 W27 U4 L4											
N13 W14 S14 D3 R3 E11 S9 E16 N4 E15\$ W15 S4 W16 N9 W11 U3											
L3 N15 W6\$ E6 N4\$ S4 E14 S13 D4 R4 E27 N14\$.											

LAND DESCRIPTION												TOTAL OB/XF												
L N	USE CODE	CLS	LAND USE DESCRIPTION	CAP	R D	LOC ZONE	FRONT	DEPTH	TOT LND UTS	UNIT TYPE	D T	DPH FACT	% COND	TOT ADJ	UNIT PRICE	ADJ UNIT PRICE	LAND VALUE	OTHER ADJUSTMENTS AND NOTES	YEAR	DENSITY	DECL	FRZ	YR	CONSRV
1	000116	C	RES MARSH	100		RSF-1	0.00	0.00	1.00	LT		1.00	1.00	1.00	390,000.00	390,000.00	390,000							

