

LOT 105  
 AMELIA CONCOURSE PH 3 UNIT B  
 OR 2365/1256

CANNON THOMAS & JANE LVG TRUST/CANNON THOMAS TRUST  
 95090 CORNFLOWER DRIVE  
 FERNANDINA BEACH, FL 32034

2025

30-2N-28-0152-0105-0000



BUILDING CHARACTERISTICS		CONSTRUCTION	
ELEMENT	CD		
Exterior Wall	31	HARDIE BRD	100
Roof Structur	03	GABLE/HIP	100
Roof Cover	03	COMP SHNGL	100
Interior Wall	05	DRYWALL	100
Interior Floor	13	LVT/LAMMT	70
Interior Floor	14	CARPET	30
Air Condition	03	CENTRAL	100
Heating Type	04	AIR DUCTED	100
Bedrooms		3	100
Bathrooms		2	100
Frame	02	WOOD FRAME	100
Stories	1.	1.	100
Units		0	100
Occupancy	00	NONE	100
Quality	04	Quality Level	04
DOR CODE	0100	SINGLE FAMILY	
MAP NUM		MKT AREA	04
NEIGHBORHOOD/LOC	4067.200		
AREA TYPE	TOTAL GROSS AREA	PCT OF BASE	YEAR
BAS	1,916	100	2021
FGR	640	55	2021
FOP	54	30	2021
FOP	126	30	2021
PTO	144	5	2021
TOTALS	2,880		

MARKET ADJUSTMENTS											
TYPE	MDL	EFF. AREA	TOT ADJ PTS	EFF. BASE RATE	REPL. COST NEW	AYB	EYB	ECON	FNCT	NORM	% COND
0100	01	2,329	112.5726	112.57	262,176	2021	2021	0	0	1.00	99.00
1 SINGLE FAM - 100% - 2022											
					Heated Area: 1916						
					HX Base Yr 2022						

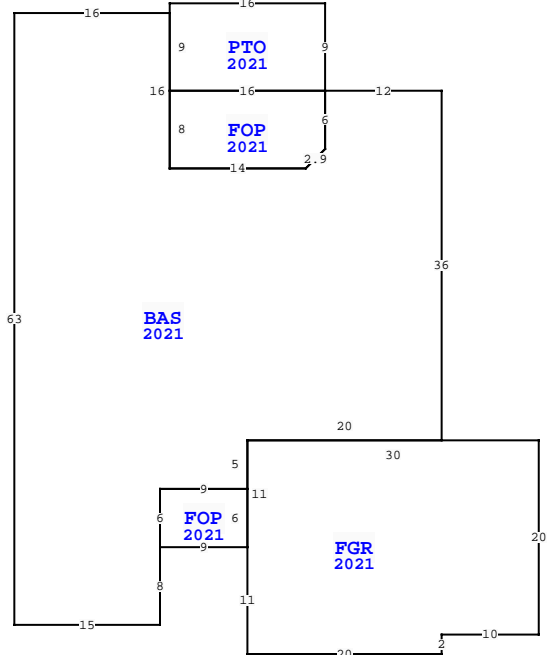

NASSAU COUNTY PROPERTY		PAGE 1 of 1	4
VALUATION SUMMARY			
VALUATION BY		STANDARD	
Tax Group: 4	Tax Dist:		
BUILDING MARKET VALUE		259,554	
TOTAL MARKET OB/XF VALUE		3,655	
TOTAL LAND VALUE - MARKET		85,000	
TOTAL MARKET VALUE		348,209	
SOH/AGL Deduction		42,253	
ASSESSED VALUE		305,956	
TOTAL EXEMPTION VALUE	HX HB	50,722	
BASE TAXABLE VALUE		255,234	
TOTAL JUST VALUE		348,209	
NCON VALUE		0	
INCOME VALUE			
PREVIOUS YEAR MKT VALUE		326,473	

PERMIT NUM	DESCRIPTION	AMT	ISSUED
C2103659	CO ISSUED	0	09/09/2021
B2103659	NEW CONSTR	289,285	03/25/2021

SALES DATA						
OFF RECORD Number	DATE	TYPE INST	Q / U	V / I	RSN CD	SALE PRICE
2495/0131	9/08/2021	WD Q	Q	I	01	338,600
GRANTOR: DREAM FINDERS HOMES L						
GRANTEE: CANNON THOMAS & JAN						
2439/1606	3/03/2021	WD U	V		30	770,000
GRANTOR: DFC AMELIA CONCOURSE						
GRANTEE: DREAM FINDERS HOMES						

EXTRA FEATURES																
L N	OB/XF CODE	DESCRIPTION	BLD CAP	L	W	UNITS	UT	Adj R	ADJ UNIT PRICE	ORIG COND	YEAR ON	YEAR ACTUAL	Q	% COND	OB/XF MKT VALUE	NOTES
1	0811	CONCRETE B	0	100	0	710.00	SF	5.20	5.20	100	2021	2021	3	99	3,655	

95090 CORNFLOWER DR, FERNANDINA BEACH

BLD DATE	03/03/2023	NW	LGL DATE	
XF DATE			LAND DATE	04/23/2025
INC DATE			AG DATE	

BUILDING NOTES	

BUILDING DIMENSIONS	
BAS=[YR=2021] W12 PTO=[YR=2021] N9 W16 S9 FOP=[YR=2021] S8 E14 U2 R2 N6 W16\$ E16\$ S6 D2 L2 W14 N16 W16 S63 E15 N8 FOP=[YR=2021] E9 FGR=[YR=2021] S11 E20 N2 E10 N20 W30 S11\$ N6 W9 S6\$ N6 E9 N5 E20 N36\$.	

LAND DESCRIPTION										TOTAL OB/XF														
L N	USE CODE	CLS	LAND USE DESCRIPTION	CAP	R D	LOC ZONE	FRONT	DEPTH	TOT LND UTS	UNIT TYPE	D T	DPH FACT	% COND	TOT ADJ	UNIT PRICE	ADJ UNIT PRICE	LAND VALUE	OTHER ADJUSTMENTS AND NOTES	YEAR	DENSITY	DECL	FRZ	YR	CONSRV
1	000100	C	RES	100		RSF-2	0.00	0.00	1.00	LT		1.00	1.00	1.00	85,000.00	85,000.00	85,000							