

LOT 60
AMELIA CONCOURSE PH 3 UNIT B
OR 2365/1256

SKARBK MICHAEL A & DENISE
95332 ORCHID BLOSSOM TR
FERNANDINA BEACH, FL 32034

2025

30-2N-28-0152-0060-0000



BUILDING CHARACTERISTICS		CONSTRUCTION	
ELEMENT	CD		
Exterior Wall	31	HARDIE BRD 100	
Roof Structur	03	GABLE/HIP 100	
Roof Cover	03	COMP SHNGL 100	
Interior Wall	05	DRYWALL 100	
Interior Floor	13	LVT/LAMMT 60	
Interior Floor	14	CARPET 40	
Air Condition	03	CENTRAL 100	
Heating Type	04	AIR DUCTED 100	
Bedrooms		5 100	
Bathrooms		3 100	
Frame	02	WOOD FRAME 100	
Stories	2.	2. 100	
Units		0 100	
Occupancy	00	NONE 100	
Quality	04	Quality Level 04	
DOR CODE	0100	SINGLE FAMILY	
MAP NUM		MKT AREA	04
NEIGHBORHOOD/LOC		4067.200	
AREA TYPE	TOTAL GROSS AREA	PCT OF BASE	YEAR
BAS	2,204	100	2021
FGR	399	55	2021
FOP	50	30	2021
FOP	120	30	2021
FUS	474	100	2021
PTO	120	5	2021
STR	20	10	2021
TOTALS	3,387		

MARKET ADJUSTMENTS											
TYPE	MDL	EFF. AREA	TOT ADJ PTS	EFF. BASE RATE	REPL. COST NEW	AYB	EYB	ECON	FNCT	NORM	% COND
1	SINGLE FAM	- 100%	- 2023								
Heated Area: 2678						HX Base Yr 2023					

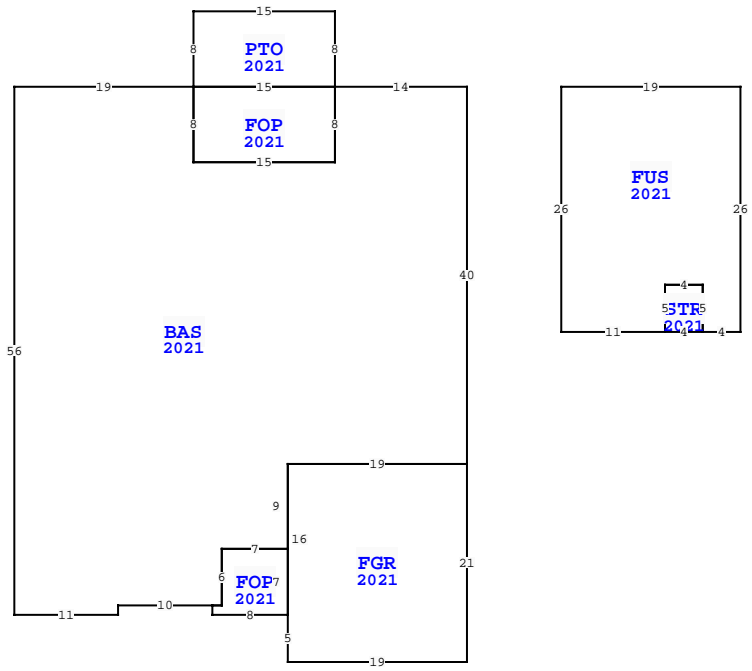

NASSAU COUNTY PROPERTY		PAGE 1 of 1	4
VALUATION SUMMARY			
VALUATION BY		STANDARD	
Tax Group: 4		Tax Dist:	
BUILDING MARKET VALUE			318,309
TOTAL MARKET OB/XF VALUE			50,701
TOTAL LAND VALUE - MARKET			85,000
TOTAL MARKET VALUE			454,010
SOH/AGL Deduction			10,871
ASSESSED VALUE			443,139
TOTAL EXEMPTION VALUE	HX HB		50,722
BASE TAXABLE VALUE			392,417
TOTAL JUST VALUE			454,010
NCON VALUE			0
INCOME VALUE			
PREVIOUS YEAR MKT VALUE			430,960

PERMIT NUM	DESCRIPTION	AMT	ISSUED
22007672	SWIM POOL	79,052	08/01/2022
C2108220	CO ISSUED	0	12/30/2021
B2108220	NEW CONSTR	377,851	06/22/2021

SALES DATA						
OFF RECORD Number	DATE	TYPE INST	Q / U	V / I	RSN CD	SALE PRICE
2529/1266	12/30/2021	WD Q	Q	I	01	438,900
GRANTOR: DREAM FINDERS HOMES L						
GRANTEE: SKARBK MICHAEL ANT						
2463/1157	5/20/2021	WD U	V	V	30	496,000
GRANTOR: DFC AMELIA CONCOURSE						
GRANTEE: DREAM FINDERS HOMES						

EXTRA FEATURES																	
L N	OB/XF CODE	DESCRIPTION	BLD	CAP	L	W	UNITS	UT	Adj R	ADJ UNIT PRICE	ORIG COND	YEAR ON	YEAR ACTUAL	Q	% COND	OB/XF MKT VALUE	NOTES
1	0811	CONCRETE B	0	100	0	0	812.00	SF	5.20	5.20	100	2021	2021	3	99	4,180	
2	0810	CONCRETE A	0	100	3	12	36.00	SF	6.50	6.50	100	2021	2021	3	99	232	
3	0861	POOL GUNIT	0	100	0	0	382.00	SF	85.00	85.00	100	2022	2022	3	95	30,847	
4	0855	CONC PAVER	0	100	0	0	658.00	SF	10.00	10.00	100	2022	2022	3	99	6,514	
5	0871	POOL HTR R	0	100	0	0	1.00	UT	2,000.00	2,000.00	100	2022	2022	3	93	1,860	
6	0462	ST/AL FNC	0	100	0	0	744.00	SF	10.00	10.00	100	2022	2022	3	95	7,068	
TOTALS																	

BLD DATE 03/03/2023 NW LGL DATE
XF DATE
INC DATE
LAND DATE 04/23/2025 MLU
AG DATE

95332 ORCHID BLOSSOM TR, FERNANDINA BEACH, FL 32034

BUILDING NOTES											
BUILDING DIMENSIONS											
BAS=[YR=2021] W14 PTO=[YR=2021] N8 W15 S8 FOP=[YR=2021] S8 E15 N8 W15\$ E15\$ S8 W15 N8 W19 S56 E11 N1 E10 FOP=[YR=2021] S1 E8 FGR=[YR=2021] S5 E19 N21 W19 S16\$ N7 W7 S6 W1\$ E1 N6 E7 N9 E19 N40\$ PTR=E10 FUS=[YR=2021] E19 S26 W4 STR=[YR=2021] W4 N5 E4 S5\$ N5 W4 S5 W11 N26\$ W10\$.											

LAND DESCRIPTION												TOTAL OB/XF												50,701				
L N	USE CODE	CLS	LAND USE DESCRIPTION	CAP	R D	LOC ZONE	FRONT	DEPTH	TOT LND UTS	UNIT TYPE	D T	DPTH FACT	% COND	TOT ADJ	UNIT PRICE	ADJ UNIT PRICE	LAND VALUE	OTHER ADJUSTMENTS AND NOTES	YEAR	DENSITY	DECL	FRZ	YR	CONSRV				
1	000100	C	RES	100		RSF-2	0.00	0.00	1.00	LT		1.00	1.00	1.00	85,000.00	85,000.00	85,000											