

BUILDING CHARACTERISTICS		
ELEMENT	CD	CONSTRUCTION
Exterior Wall	10	ABOVE AVG 100
Roof Structur	03	GABLE/HIP 100
Roof Cover	03	COMP SHNGL 100
Interior Wall	05	DRYWALL 100
Interior Floor	12	HARDWOOD 50
Interior Floor	14	CARPET 50
Air Condition	03	CENTRAL 100
Heating Type	04	AIR DUCTED 100
Bedrooms		4 100
Bathrooms		4.5 100
Frame	02	WOOD FRAME 100
Stories	2.	2. 100
Units		0 100
BUD8 Adjustme	05	DIST 1A 100
Occupancy	00	NONE 100

MARKET ADJUSTMENTS												
TYPE	MDL	EFF. AREA	TOT ADJ PTS	EFF. BASE RATE	REPL. COST NEW	AYB	EYB	ECON	FNCT	NORM	% COND	
0500	01	4,182	99.0000	156.42	654,148	1982	1987	0	0	0	16.25	83.75

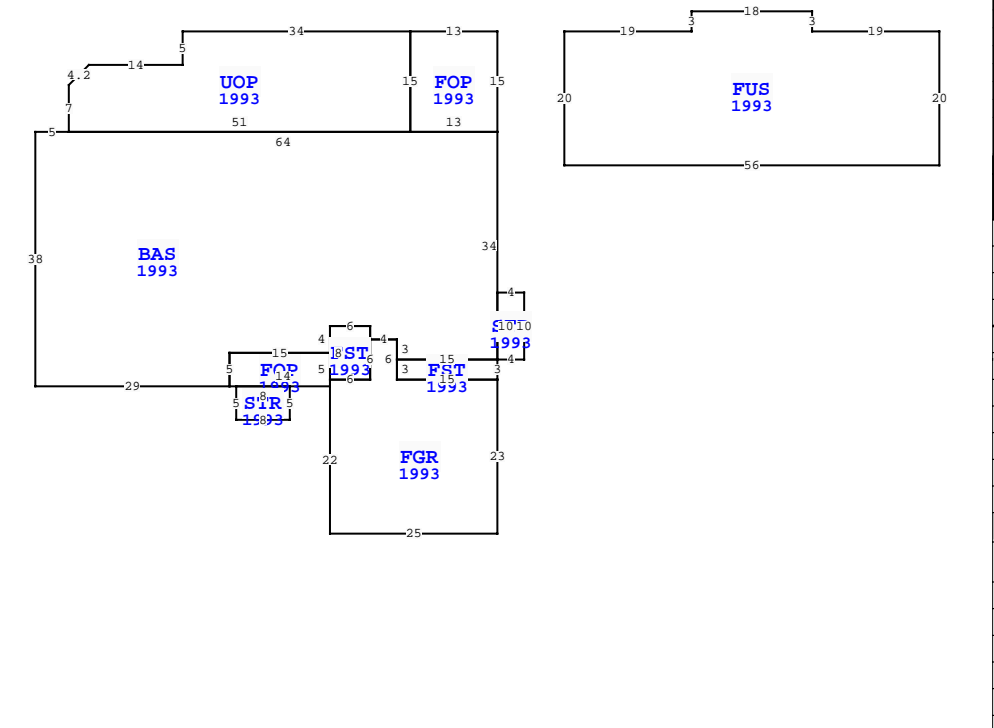

Quality		03 Quality Level 03			
DOR CODE		0100 SINGLE FAMILY			
MAP NUM		MKT AREA 10			
NEIGHBORHOOD/LOC 10001.00					
AREA TYPE	TOTAL GROSS AREA	PCT OF BASE	YEAR	TOT ADJ AREA	SUBAREA MARKET VALUE
BAS	2,405	100	1993	2,405	315,059
FGR	599	55	1993	329	43,099
FOP	75	30	1993	22	2,882
FOP	195	30	1993	58	7,598
FST	45	55	1993	25	3,275
FST	48	55	1993	26	3,406
FUS	1,174	100	1993	1,174	153,796
STP	40	10	1993	4	524
STR	40	10	1993	4	524
UOP	676	20	1993	135	17,685
TOTALS	5,297			4,182	547,849

34 MARSH CREEK RD, FERNANDINA BEACH

BLD DATE		LGL DATE	
XF DATE		LAND DATE	05/07/2025
INC DATE		AG DATE	MLU

EXTRA FEATURES																	
L N	OB/XF CODE	DESCRIPTION	BLD	CAP	L	W	UNITS	UT	Adj R	ADJ UNIT PRICE	ORIG COND	YEAR ON	YEAR ACTUAL	Q	% COND	OB/XF MKT VALUE	NOTES
1	0504	FP-ELECTRI	0	100	0	0	1.00	UT	2,000.00	2,000.00	100	1982	1982	3	49	980	
2	0810	CONCRETE A	0	100	0	0	120.00	SF	6.50	6.50	100	1982	1982	3	35	273	
3	0855	CONC PAVER	0	100	0	0	1,450.00	SF	10.00	10.00	100	1985	1985	3	44	6,380	
4	0300	BOAT DCK W	0	100	0	0	2,140.00	SF	40.00	40.00	100	1985	1985	3	20	17,120	
5	0445	BOX FNC 5'	0	100	0	0	34.00	LF	8.10	8.10	100	1985	1985	3	20	55	

TOTAL OB/XF													24,808				
-------------	--	--	--	--	--	--	--	--	--	--	--	--	--------	--	--	--	--

LAND DESCRIPTION																								
L N	USE CODE	CLS	LAND USE DESCRIPTION	CAP	R D	LOC ZONE	FRONT	DEPTH	TOT LND UTS	UNIT TYPE	D T	DPHT FACT	% COND	TOT ADJ	UNIT PRICE	ADJ UNIT PRICE	LAND VALUE	OTHER ADJUSTMENTS AND NOTES	YEAR	DENSITY	DECL	FRZ	YR	CONSRV
1	000131	C	RES CREEK	100		RSF-1	0.00	0.00	1.00	LT		1.00	1.00	1.00	850,000.00	850,000.00	850,000							

NASSAU COUNTY PROPERTY				PAGE 1 of 1				5			
VALUATION SUMMARY											
VALUATION BY				STANDARD							
Tax Group: 5				Tax Dist:							
BUILDING MARKET VALUE				547,849							
TOTAL MARKET OB/XF VALUE				24,808							
TOTAL LAND VALUE - MARKET				850,000							
TOTAL MARKET VALUE				1,422,657							
SOH/AGL Deduction				368,145							
ASSESSED VALUE				1,054,512							
TOTAL EXEMPTION VALUE				HX HB 50,722							
BASE TAXABLE VALUE				1,003,790							
TOTAL JUST VALUE				1,422,657							
NCON VALUE				0							
INCOME VALUE											
PREVIOUS YEAR MKT VALUE				1,296,979							

PERMIT NUM	DESCRIPTION	AMT	ISSUED

SALES DATA						
OFF RECORD Number	DATE	TYPE INST	Q U	V I	RSN CD	SALE PRICE
1286/0250	1/06/2005	WD	U	I	21	995,000
GRANTOR: MATHES WALLACE E JR &						
GRANTEE: BURGE RICHARD D & P						
0613/0577	12/04/1990	WD	Q	I	01	100
GRANTOR: MATHES WALLACE E JR						
GRANTEE: MATHES WALLACE & D						

BUILDING NOTES												

BUILDING DIMENSIONS												
FOP=[YR=1993] W13 UOP=[YR=1993] W34 S5 W14 D3 L3 S7												
BAS=[YR=1993] W5 S38 E29 FOP=[YR=1993] E1 STR=[YR=1993] S5												
E8 N5 W8\$ E14 FGR=[YR=1993] S22 E25 N23 FST=[YR=1993] N3												
W15 S3 E15 \$ W15 N6 W4 FST=[YR=1993] N2 W6 S8 E6 N6\$ S6 W6												
S1\$ N5 W15 S5\$ N5 E15 N4 E6 S2 E4 S3 E15 STP=[YR=1993] E4												
N10 W4 S10\$ N34 W64\$ E51 N15\$ S15 E13 N15\$ PTR= E10												
FUS=[YR=1993] E19 N3 E18 S3 E19 S20 W56 N20\$ W10\$.												