

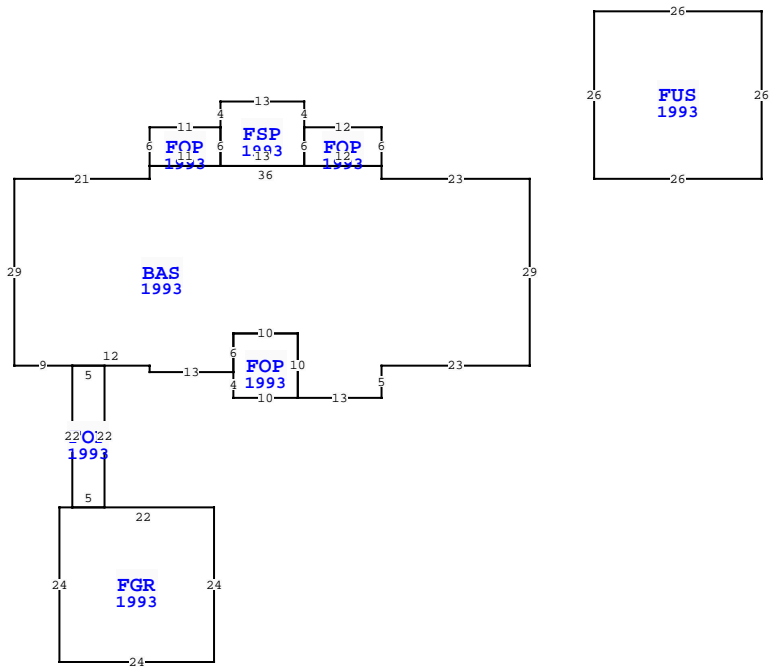

ELEMENT		CD	CONSTRUCTION		
Exterior Wall	12	CEDAR	60		
Exterior Wall	16	WD FR STUC	40		
Roof Structure	03	GABLE/HIP	100		
Roof Cover	03	COMP SHNGL	100		
Interior Wall	05	DRYWALL	100		
Interior Floor	12	HARDWOOD	50		
Interior Floor	14	CARPET	50		
Air Condition	03	CENTRAL	100		
Heating Type	04	AIR DUCTED	100		
Bedrooms		3	100		
Bathrooms		4.5	100		
Frame	02	WOOD FRAME	100		
Stories	2.	2.100			
Units		0	100		
BUD8 Adjustme	05	DIST 1A	100		
Occupancy	00	NONE	100		
Quality	04	Quality Level 04			
DOR CODE	0100	SINGLE FAMILY			
MAP NUM		MKT AREA	10		
NEIGHBORHOOD/LOC	10001.00				
AREA TYPE	TOTAL GROSS AREA	PCT OF BASE	YEAR	TOT ADJ AREA	SUBAREA MARKET VALUE
BAS	2,420	100	1993	2,420	329,116
FGR	576	55	1993	317	43,112
FOP	66	30	1993	20	2,720
FOP	72	30	1993	22	2,992
FOP	100	30	1993	30	4,080
FOP	110	30	1993	33	4,488
FSP	130	40	1993	52	7,072
FUS	676	100	1993	676	91,935
TOTALS	4,150			3,570	485,515

MARKET ADJUSTMENTS											
TYPE	MDL	EFF. AREA	TOT ADJ PTS	EFF. BASE RATE	REPL. COST NEW	AYB	EYB	ECON	FNCT	NORM	% COND
1	SFR CUST	- 100%	- 2024		Heated Area: 3096					HX Base Yr 2024	



VALUATION BY		STANDARD
Tax Group: 5	Tax Dist:	
BUILDING MARKET VALUE		485,515
TOTAL MARKET OB/XF VALUE		12,499
TOTAL LAND VALUE - MARKET		700,000
TOTAL MARKET VALUE		1,198,014
SOH/AGL Deduction		421,060
ASSESSED VALUE		776,954
TOTAL EXEMPTION VALUE	HX HB	50,722
BASE TAXABLE VALUE		726,232
TOTAL JUST VALUE		1,198,014
NCON VALUE		0
INCOME VALUE		
PREVIOUS YEAR MKT VALUE		1,126,783

PERMIT NUM	DESCRIPTION	AMT	ISSUED
R046247	REPAIR/RRF	1,100	06/01/2004
5466	REMODEL	1,500	10/26/1988
5155	ADDITION	16,050	09/12/1988

SALES DATA						
OFF RECORD Number	DATE	TYPE INST	Q / V / I	RSN CD	SALE PRICE	
2635/963	5/01/2023	WD Q	I	02	1,410,000	
GRANTOR: COBLE SAMUEL N & SAND						
GRANTEE: FENN DRAKE TRUST						
2296/1737	8/07/2019	WD Q	I	02	680,000	
GRANTOR: FULLER BARBARA D						
GRANTEE: COBLE SAMUEL N & SA						

EXTRA FEATURES																
L N	OB/XF CODE	DESCRIPTION	BLD CAP	L	W	UNITS	UT	Adj R	ADJ UNIT PRICE	ORIG COND	YEAR ON	YEAR ACTUAL	Q	% COND	OB/XF MKT VALUE	NOTES
1	0504	FP-ELECTRI	0	100	0	1.00	UT	2,000.00	2,000.00	100	1982	1982	3	49	980	
2	0812	CONCRETE C	0	100	0	2,240.00	SF	4.00	4.00	100	1983	1983	3	38	3,405	
3	0825	BRICK	0	100	0	787.00	SF	12.50	12.50	100	1984	1984	3	79	7,772	
4	1242	WD DECK A	0	100	19	171.00	SF	10.00	10.00	100	1982	1982	3	20	342	

BLD DATE		LGL DATE	
XF DATE	INC DATE	LAND DATE	AG DATE
		05/07/2025	MLU

BUILDING NOTES	
BUILDING DIMENSIONS	
BAS=[YR=1993] W23 N2 FOP=[YR=1993] N6 W12 FSP=[YR=1993] N4 W13 S4 FOP=[YR=1993] W11 S6 E11 N6\$ S6 E13 N6\$ S6 E12\$ W36 S2 W21 S29 E9 FOP=[YR=1993] S22 FGR=[YR=1993] W2 S24 E24 N24 W22\$ E5 N22 W5\$ E12 S1 E13 FOP=[YR=1993] S4 E10 N10 W10 S6\$ N6 E10 S10 E13 N5 E23 N29\$ PTR= E10 FUS=[YR=1993] E26 N26 W26 S26\$ W10\$.	

LAND DESCRIPTION															TOTAL OB/XF									
L N	USE CODE	CLS	LAND USE DESCRIPTION	CAP	R D	LOC ZONE	FRONT	DEPTH	TOT LND UTS	UNIT TYPE	D T	DPH FACT	% COND	TOT ADJ	UNIT PRICE	ADJ UNIT PRICE	LAND VALUE	OTHER ADJUSTMENTS AND NOTES	YEAR	DENSITY	DECL	FRZ	YR	CONSRV
1	000140	C	RES GOLF	100		RSF-1	0.00	0.00	1.00	LT		1.00	1.00	1.00	700,000.00	700,000.00	700,000							