

LOT 11
IN OR 1071/681
SUMMER BEACH WEST REPLAT

HEGARTY DENNIS S & SABINA S
95128 WOODBERRY LANE
FERNANDINA BEACH, FL 32034

2025

00-SB-30-197W-0011-0000

BUILDING CHARACTERISTICS		CONSTRUCTION	
ELEMENT	CD		
Exterior Wall	16	WD FR STUC	100
Roof Structur	08	IRREGULAR	100
Roof Cover	03	COMP SHNGL	100
Interior Wall	05	DRYWALL	100
Interior Floo	11	CLAY TILE	70
Interior Floo	14	CARPET	30
Air Condition	03	CENTRAL	100
Heating Type	04	AIR DUCTED	100
Bedrooms		5	100
Bathrooms		3	100
Frame	02	WOOD FRAME	100
Stories	1.	1. 100	
Units		0	100
Quality	04	Quality Level 04	
DOR CODE	0100	SINGLE FAMILY	
MAP NUM		MKT AREA	03
NEIGHBORHOOD/LOC	3021.00		
AREA TYPE	TOTAL GROSS AREA	PCT OF BASE	YEAR
BAS	1,877	100	2002
FGR	420	55	2002
FOP	64	30	2002
FSP	185	40	2002
FUS	365	100	2002
PTO	91	5	2002
TOTALS	3,002		

MARKET ADJUSTMENTS											
TYPE	MDL	EFF. AREA	TOT ADJ PTS	EFF. BASE RATE	REPL. COST NEW	AYB	EYB	ECON	FNCT	NORM	% COND
1	SFR	CUST	- 100%	- 2003							
Heated Area: 2242						HX Base Yr 2003					

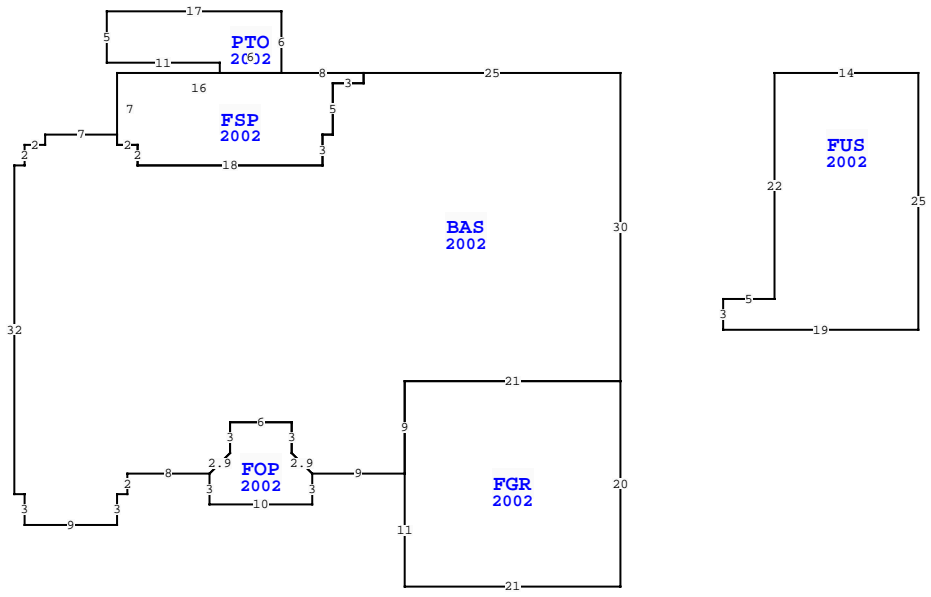

NASSAU COUNTY PROPERTY		PAGE 1 of 1	8
VALUATION SUMMARY			
VALUATION BY	STANDARD		
Tax Group: 8	Tax Dist:		
BUILDING MARKET VALUE	559,393		
TOTAL MARKET OB/XF VALUE	6,821		
TOTAL LAND VALUE - MARKET	175,000		
TOTAL MARKET VALUE	741,214		
SOH/AGL Deduction	360,670		
ASSESSED VALUE	380,544		
TOTAL EXEMPTION VALUE	50,722		
BASE TAXABLE VALUE	329,822		
TOTAL JUST VALUE	741,214		
NCON VALUE	0		
INCOME VALUE			
PREVIOUS YEAR MKT VALUE	716,001		

PERMIT NUM	DESCRIPTION	AMT	ISSUED
B0108693	NEW CONSTR	189,000	08/01/2001

SALES DATA						
OFF RECORD Number	DATE	TYPE INST	Q U	V I	RSN CD	SALE PRICE
1071/0681	7/26/2002	WD Q	Q	I		369,100

GRANTOR: SUMMER BEACH WEST LLC
GRANTEE: HEGARTY DENNIS S &

BUILDING NOTES	
<p>BUILDING DIMENSIONS BAS=[YR=2002] W25 FSP=[YR=2002] W8 PTO=[YR=2002] N6 W17 S5 E11 S1 E6 \$ W16 S7 E2 S2 E18 N3 E1 N5 E3 N1 \$ S1 W3 S5 W1 S3 W18 N2 W2 N1 W7 S1 W2 S2 W1 S32 E1 S3 E9 N3 E1 N2 E8 POP=[YR=2002] S3 E10 N3 U2 L2 N3 W6 S3 D2 L2 \$ U2 R2 N3 E6 S3 D2 R2 E9 FGR=[YR=2002] S11 E21 N20 W21 S9 \$ N9 E21 N30 \$ PTR= E15 FUS=[YR=2002] E14 S25 W19 N3 E5 N22 \$ W15 \$.</p>	

EXTRA FEATURES																
L N	OB/XF CODE	DESCRIPTION	BLD CAP	L	W	UNITS	UT	Adj R	ADJ UNIT PRICE	ORIG COND	YEAR ON	YEAR ACTUAL	Q	% COND	OB/XF MKT VALUE	NOTES
1	0500	FP-PRE FAB	0	100	0	1.00	UT	3,500.00	3,500.00	100	2002	2002	3	85	2,975	
2	0811	CONCRETE B	0	100	0	762.00	SF	5.20	5.20	100	2002	2002	3	80	3,170	
3	0810	CONCRETE A	0	100	0	130.00	SF	6.50	6.50	100	2002	2002	3	80	676	

LAND DESCRIPTION		TOTAL OB/XF																						
L N	USE CODE	CLS	LAND USE DESCRIPTION	CAP	R D	LOC ZONE	FRONT	DEPTH	TOT LND UTS	UNIT TYPE	D T	DPH FACT	% COND	TOT ADJ	UNIT PRICE	ADJ UNIT PRICE	LAND VALUE	OTHER ADJUSTMENTS AND NOTES	YEAR	DENSITY	DECL	FRZ	YR	CONSRV
1	000100	C	RES	100		PUD	0.00	0.00	1.00	LT		1.00	1.00	1.00	175,000.00	175,000.00	175,000							