

BUILDING CHARACTERISTICS		
ELEMENT	CD	CONSTRUCTION
Exterior Wall	16	WD FR STUC 100
Roof Structur	08	IRREGULAR 100
Roof Cover	08	CLAY TILE 100
Interior Wall	05	DRYWALL 100
Interior Floor	11	CLAY TILE 100
Air Condition	03	CENTRAL 100
Heating Type	04	AIR DUCTED 100
Bedrooms		4 100
Bathrooms		3 100
Frame	02	WOOD FRAME 100
Stories	2.	2. 100
Units		0 100
Occupancy	00	NONE 100

MARKET ADJUSTMENTS													
TYPE	MDL	EFF. AREA	TOT ADJ PTS	EFF. BASE RATE	REPL. COST NEW	AYB	EYB	ECON	FNCT	NORM	% COND		
0500	11	2,743	159.7152	252.35	692,196	2020	2020	0	0	2.00	98.00		
1 SFR CUST - 100% - 2021 Heated Area: 2442 HX Base Yr 2021													

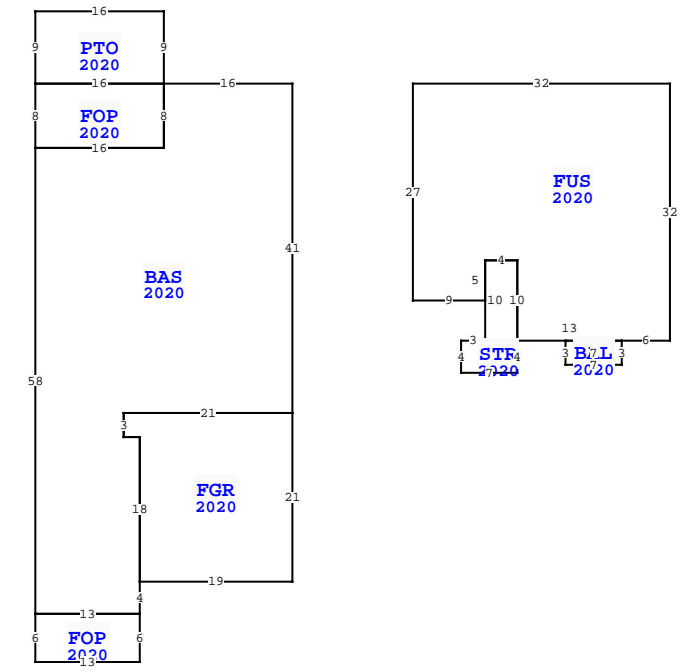

Quality	03	Quality Level 03			
DOR CODE	0100	SINGLE FAMILY			
MAP NUM		MKT AREA 03			
NEIGHBORHOOD/LOC	3043.100				
AREA TYPE	TOTAL GROSS AREA	PCT OF BASE	YEAR	TOT ADJ AREA	SUBAREA MARKET VALUE
BAL	21	15	2020	3	742
BAS	1,503	100	2020	1,503	371,696
FGR	405	55	2020	223	55,149
FOP	78	30	2020	23	5,688
FOP	128	30	2020	38	9,397
FUS	939	100	2020	939	232,218
PTO	144	5	2020	7	1,731
STR	68	10	2020	7	1,731
TOTALS	3,286			2,743	678,352

NASSAU COUNTY PROPERTY			PAGE 1 of 1	8
VALUATION SUMMARY				
VALUATION BY	STANDARD			
Tax Group: 8	Tax Dist:			
BUILDING MARKET VALUE	678,352			
TOTAL MARKET OB/XF VALUE	4,626			
TOTAL LAND VALUE - MARKET	165,000			
TOTAL MARKET VALUE	847,978			
SOH/AGL Deduction	329,508			
ASSESSED VALUE	518,470			
TOTAL EXEMPTION VALUE	HX HB VX 55,722			
BASE TAXABLE VALUE	462,748			
TOTAL JUST VALUE	847,978			
NCON VALUE	0			
INCOME VALUE	0			
PREVIOUS YEAR MKT VALUE	816,956			

PERMIT NUM	DESCRIPTION	AMT	ISSUED
19007674	NEW CONSTR	318,355	07/18/2019

SALES DATA						
OFF RECORD Number	DATE	TYPE INST	Q / U	V / I	RSN CD	SALE PRICE
2785/270	4/14/2025	SW	U	I	11	100
GRANTOR: BURNS BARBARA T						
GRANTEE: BURNS BARBARA T REV						
2353/1580	4/09/2020	SW	Q	I	02	559,000
GRANTOR: ARTISAN HOMES LLC						
GRANTEE: BURNS DAVID C & BAR						

EXTRA FEATURES																
L N	OB/XF CODE	DESCRIPTION	BLD CAP	L	W	UNITS	UT	Adj R	ADJ UNIT PRICE	ORIG COND	YEAR ON	YEAR ACTUAL	Q	% COND	OB/XF MKT VALUE	NOTES
1	0855	CONC PAVER	0	100	0	436.00	SF	10.00	10.00	100	2020	2020	3	98	4,273	
2	0855	CONC PAVER	0	100	0	36.00	SF	10.00	10.00	100	2020	2020	3	98	353	

BLD DATE		LGL DATE	
XF DATE		LAND DATE	04/15/2024
INC DATE		AG DATE	MLU
96059 BOTTLEBRUSH LN, FERNANDINA BEACH			

BUILDING NOTES													
BUILDING DIMENSIONS													

BAS=[YR=2020] W16 PTO=[YR=2020] N9 W16 S9 FOP=[YR=2020] S8 E16 N8 W16\$ E16\$ S8 W16 S58 FOP=[YR=2020] S6 E13 N6 W13\$ E13 N4 FGR=[YR=2020] E19 N21 W21 S3 E2 S18\$ N18 W2 N3 E21 N41\$ PTR=E15 FUS=[YR=2020] E32 S32 W6 BAL=[YR=2020] S3 W7 N3 E7\$ W13 STR=[YR=2020] S4 W7 N4 E3 N10 E4 S10 \$ N10 W4 S5 W9 N27\$ W15\$.

LAND DESCRIPTION														TOTAL OB/XF										
L N	USE CODE	CLS	LAND USE DESCRIPTION	CAP	R D	LOC ZONE	FRONT	DEPTH	TOT LND UTS	UNIT TYPE	D T	DPH FACT	% COND	TOT ADJ	UNIT PRICE	ADJ UNIT PRICE	LAND VALUE	OTHER ADJUSTMENTS AND NOTES	YEAR	DENSITY	DECL	FRZ	YR	CONSRV
1	000100	C	RES	100		PUD	0.00	0.00	1.00	LT		1.00	1.00	1.00	165,000.00	165,000.00	165,000							