

BUILDING CHARACTERISTICS		
ELEMENT	CD	CONSTRUCTION
Exterior Wall	31	HARDIE BRD 100
Roof Structur	03	GABLE/HIP 100
Roof Cover	12	MODULAR MT 100
Interior Wall	05	DRYWALL 100
Interior Floor	11	CLAY TILE 100
Interior Floor	14	CARPET 0
Air Condition	03	CENTRAL 100
Heating Type	04	AIR DUCTED 100
Bedrooms		3 100
Bathrooms		3.5 100
Frame	02	WOOD FRAME 100
Stories	3.	3. 100
Units		0 100
Occupancy	00	NONE 100

MARKET ADJUSTMENTS												
TYPE	MDL	EFF. AREA	TOT ADJ PTS	EFF. BASE RATE	REPL. COST NEW	AYB	EYB	ECON	FNCT	NORM	% COND	
1	SFR CUST	- 100%	- 2025									

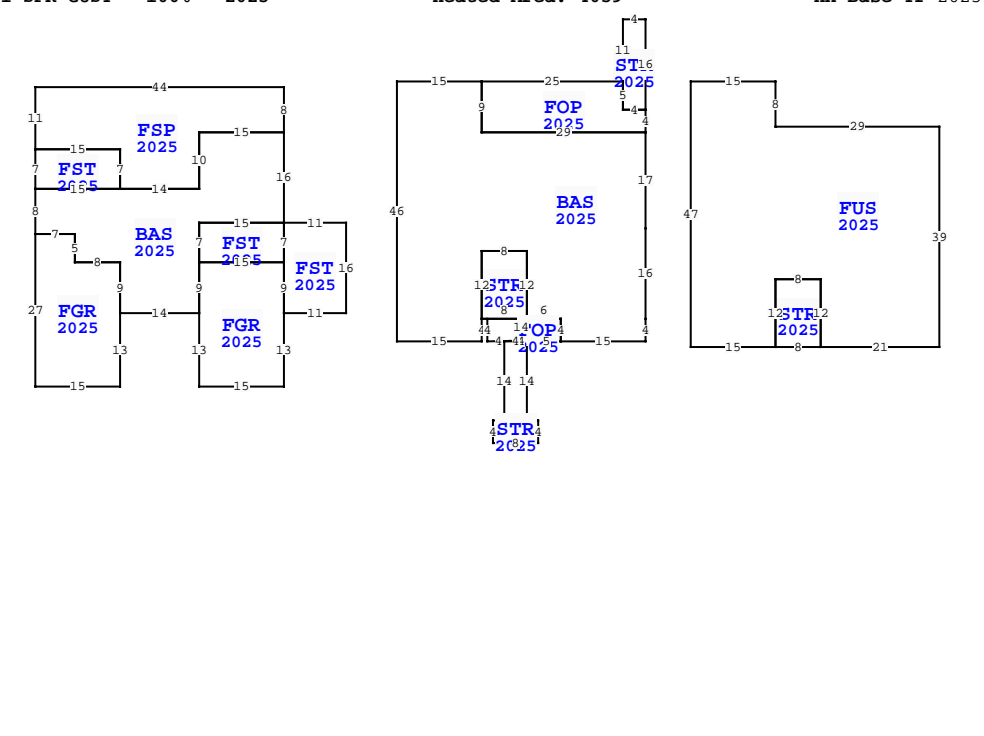

NASSAU COUNTY PROPERTY		PAGE 1 of 1	2
VALUATION SUMMARY			
VALUATION BY	STANDARD		
Tax Group: 2	Tax Dist:		
BUILDING MARKET VALUE	1,146,561		
TOTAL MARKET OB/XF VALUE	89,972		
TOTAL LAND VALUE - MARKET	720,000		
TOTAL MARKET VALUE	1,956,533		
SOH/AGL Deduction	0		
ASSESSED VALUE	1,956,533		
TOTAL EXEMPTION VALUE	HX HB 50,722		
BASE TAXABLE VALUE	1,905,811		
TOTAL JUST VALUE	1,956,533		
NCON VALUE	1,228,253		
INCOME VALUE			
PREVIOUS YEAR MKT VALUE	540,000		

Quality	06	Quality Level 06			
DOR CODE	0100	SINGLE FAMILY			
MAP NUM		MKT AREA 01			
NEIGHBORHOOD/LOC	1044.00				
AREA TYPE	TOTAL GROSS AREA	PCT OF BASE	YEAR	TOT ADJ AREA	SUBAREA MARKET VALUE
BAS	708	100	2025	708	162,776
BAS	1,611	100	2025	1,611	370,385
FGR	330	55	2025	182	41,844
FGR	365	55	2025	201	46,212
FOP	35	30	2025	10	2,299
FOP	241	30	2025	72	16,554
FSP	537	40	2025	215	49,431
FST	105	55	2025	58	13,335
FST	105	55	2025	58	13,335
FST	176	55	2025	97	22,301
TOTALS	6,297			4,987	1,146,561

** This building has 15 Sub-Areas
3535 1ST AVE, FERNANDINA BEACH

BLD DATE		LGL DATE	
XF DATE		LAND DATE	05/08/2025
INC DATE		AG DATE	MLU

PERMIT NUM	DESCRIPTION	AMT	ISSUED
BLDR-2023-0	POOL ENCL	37,202	08/05/2024
2023-0138			04/18/2023
20222382	NEW CONSTR	576,411	12/12/2022
2022-2382			

SALES DATA						
OFF RECORD Number	DATE	TYPE INST	Q / U	V / I	RSN CD	SALE PRICE
2613/0723	12/20/2022	WD	Q	V	01	260,000
GRANTOR: SOLIS DEBORAH A						
GRANTEE: HATTON RANDY C & CY						
1924/1496	6/23/2014	WD	Q	V	01	120,000
GRANTOR: CONRAD JOANNE L						
GRANTEE: HATTON RANDY C & CY						

EXTRA FEATURES																	
L N	OB/XF CODE	DESCRIPTION	BLD CAP	L	W	UNITS	UT	Adj R	ADJ UNIT PRICE	ORIG COND	YEAR ON	YEAR ACTUAL	Q	% COND	OB/XF MKT VALUE	NOTES	
1	0855	CONC PAVER	0	100	0	0			1,858.00	SF	10.00	10.00	100	2025	2024	100	18,580
2	0600	SUMMER KIT	0	100	0	0			1.00	UT	5,000.00	5,000.00	100	2025	2024	100	5,000
3	0861	POOL GUNIT	0	100	0	0			360.00	SF	85.00	85.00	100	2025	2024	100	30,600
4	0912	SCRN RM G	0	100	0	0			1,188.00	SF	20.00	20.00	100	2025	2024	100	23,760
5	0871	POOL HTR R	0	100	0	0			1.00	UT	2,000.00	2,000.00	100	2025	2024	100	2,000
6	0476	VF 6 SBPL	0	100	0	0			36.00	LF	32.00	32.00	100	2025	2024	100	1,152
7	0470	VNYL GATE	0	100	0	0			2.00	UT	300.00	300.00	100	2025	2024	100	600
8	0855	CONC PAVER	0	100	0	0			828.00	SF	10.00	10.00	100	2025	2024	100	8,280

TOTAL OB/XF													89,972				

BUILDING NOTES												
BAS=[YR=2025;ORIG=-30,0] W15 S10 W14 W15 S8 E7 S5 E8 S9 E14 N9 N7 E15 N16 \$												
FST=[YR=2025;ORIG=-74,3] E15 S7 W15 N7 \$												
FSP=[YR=2025;ORIG=-74,3] E15 S7 E14 N10 E15 N8 W44 S11 \$												
FST=[YR=2025;ORIG=-30,16] E11 S16 W11 N9 N7 \$												
FGR=[YR=2025;ORIG=-45,23] E15 S9 S13 W15 N13 N9 \$												
FGR=[YR=2025;ORIG=-74,18] E7 S5 E8 S9 S13 W15 N27 \$												
BAS=[YR=2025;ORIG=-10,-9] E15 S9 E29 S17 S16 S4 W15 N4 W6 N12 W8 S12 S4 W15 N46 \$												
FOP=[YR=2025;ORIG=5,-9] E25 S5 E4 S4 W29 N9 \$												
STR=[YR=2025;ORIG=30,-20] S11 S5 E4 N16 W4 \$												
FOP=[YR=2025;ORIG=5,33] E14 S4 D0L5 U0.1L4 D0.1L4 N4 \$												

LAND DESCRIPTION													TOTAL OB/XF												
L N	USE CODE	CLS	LAND USE DESCRIPTION	CAP	R D	LOC ZONE	FRONT	DEPTH	TOT LND UTS	UNIT TYPE	D T	DPTH FACT	% COND	TOT ADJ	UNIT PRICE	ADJ UNIT PRICE	LAND VALUE	OTHER ADJUSTMENTS AND NOTES	YEAR	DENSITY	DECL	FRZ	YR	CONSRV	
1	000100	C	RES	100		R-1	150.00	100.00	150.00	FF		1.00	1.00	0.40	6,000.00	2,400.00	360,000								
2	000100	C	RES	100		R-1	150.00	100.00	150.00	FF		1.00	1.00	0.40	6,000.00	2,400.00	360,000								