

LOT 70  
IN OR 837/1820  
PARKWAY NORTH PB 5/263

PETERS CARL E & DEBORAH T  
1535 CANOPY DRIVE  
FERNANDINA BEACH, FL 32034-5317

**2025**

00-00-31-163N-0070-0000

BUILDING CHARACTERISTICS		CONSTRUCTION	
ELEMENT	CD		
Exterior Wall	16	WD FR STUC	100
Roof Structur	03	GABLE/HIP	100
Roof Cover	03	COMP SHNGL	100
Interior Wall	05	DRYWALL	100
Interior Floor	14	CARPET	60
Interior Floor	12	HARDWOOD	40
Air Condition	03	CENTRAL	100
Heating Type	04	AIR DUCTED	100
Bedrooms	4	100	
Bathrooms	4.5	100	
Frame	02	WOOD FRAME	100
Stories	1.	1. 100	
Units	0	0 100	
Occupancy	00	NONE	100
Quality	05	Quality Level 05	
DOR CODE	0100	SINGLE FAMILY	
MAP NUM		MKT AREA	01
NEIGHBORHOOD/LOC	1072.00		
AREA TYPE	TOTAL GROSS AREA	PCT OF BASE	YEAR
BAS	3,072	100	2001
FGR	1,063	55	2001
FOP	50	30	2001
FOP	284	30	2001
PTO	36	5	2001
UOP	42	20	2001
TOTALS	4,547		

MARKET ADJUSTMENTS											
TYPE	MDL	EFF. AREA	TOT ADJ PTS	EFF. BASE RATE	REPL. COST NEW	AYB	EYB	ECON	FNCT	NORM	% COND
0500	01	3,767	111.8700	176.75	665,817	2001	2001	0	0	11.50	88.50
1 SFR CUST - 100% - 2002 Heated Area: 3072 HX Base Yr 2002											

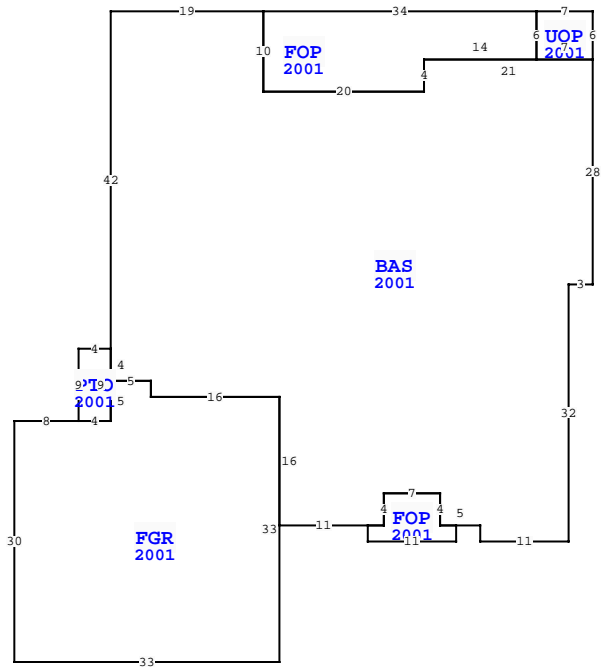

NASSAU COUNTY PROPERTY			
VALUATION SUMMARY			PAGE 1 of 1
VALUATION BY			STANDARD
Tax Group: 2	Tax Dist:		
BUILDING MARKET VALUE			589,248
TOTAL MARKET OB/XF VALUE			11,905
TOTAL LAND VALUE - MARKET			200,000
TOTAL MARKET VALUE			801,153
SOH/AGL Deduction			445,923
ASSESSED VALUE			355,230
TOTAL EXEMPTION VALUE	HX HB		50,722
BASE TAXABLE VALUE			304,508
TOTAL JUST VALUE			801,153
NCON VALUE			0
INCOME VALUE			
PREVIOUS YEAR MKT VALUE			774,544

PERMIT NUM	DESCRIPTION	AMT	ISSUED
B2004037	NEW CONSTR	198,000	09/21/2000

SALES DATA						
OFF RECORD Number	DATE	TYPE INST	Q / U	V / I	RSN CD	SALE PRICE
0837/1820	6/16/1998	WD Q	Q	V		47,500
GRANTOR: ZEITLIN JOHN A						
GRANTEE: PETERS CARL E & DEB						
0599/0620	6/11/1990	WD U	V	07		100
GRANTOR: EMBRY DEV CORP						
GRANTEE: ZEITLIN JOHN A						

EXTRA FEATURES											
L N	OB/XF CODE	DESCRIPTION	BLD CAP	L	W	UNITS	UT	Adj R	ADJ UNIT PRICE	ORIG COND	YEAR ON
1	0812	CONCRETE C	0	100	0	1,509.00	SF	4.00	4.00	100	2001
2	0810	CONCRETE A	0	100	8	24.00	SF	6.50	6.50	100	2001
3	0858	SCULP CONC	0	100	0	289.00	SF	13.00	13.00	100	2001
4	1126	CB/STC 8"	0	100	0	52.00	SF	8.00	8.00	100	2001
5	0858	SCULP CONC	0	100	0	258.00	SF	13.00	13.00	100	2001

TOTAL OB/XF											
L N	USE CODE	CLS	LAND USE DESCRIPTION	CAP	R D	LOC ZONE	FRONT	DEPTH	TOT LND UTS	UNIT TYPE	D T
1	000100	C	RES	100		R1-G	0.00	0.00	1.00	UT	1.00

BUILDING NOTES			

BUILDING DIMENSIONS			
UOP=[YR=2001] W7 FOP=[YR=2001] W34 BAS=[YR=2001] W19 S42			
PTO=[YR=2001] W4 S9 FGR=[YR=2001] W8 S30 E33 N33 W16 N2 W5			
S5 W4 \$ E4 N9 \$ S4 E5 S2 E16 S16 E11 FOP=[YR=2001] S2 E11 N2			
W2 N4 W7 S4 W2 \$ E2 N4 E7 S4 E5 S2 E11 N32 E3 N28 W21 S4 W20			
N10 \$ S10 E20 N4 E14 N6 \$ S6 E7 N6 \$ .			

LAND DESCRIPTION											
L N	USE CODE	CLS	LAND USE DESCRIPTION	CAP	R D	LOC ZONE	FRONT	DEPTH	TOT LND UTS	UNIT TYPE	D T
1	000100	C	RES	100		R1-G	0.00	0.00	1.00	UT	1.00