

LOT 52
IN OR 1714/414
PARKWAY NORTH PB 5/263

WILSON ELIZABETH F & KENNETH E
1583 CANOPY DRIVE
FERNANDINA BEACH, FL 32034

2025

00-00-31-163N-0052-0000

ELEMENT	CD	CONSTRUCTION
Exterior Wall	16	WD FR STUC 100
Roof Structur	03	GABLE/HIP 100
Roof Cover	03	COMP SHNGL 100
Interior Wall	05	DRYWALL 100
Interior Floo	14	CARPET 80
Interior Floo	11	CLAY TILE 20
Air Condition	03	CENTRAL 100
Heating Type	04	AIR DUCTED 100
Bedrooms	3	100
Bathrooms	2	100
Frame	02	WOOD FRAME 100
Stories	2.	2. 100
Units	0	100
Occupancy	00	NONE 100

MARKET ADJUSTMENTS											
TYPE	MDL	EFF. AREA	TOT ADJ PTS	EFF. BASE RATE	REPL. COST NEW	AYB	EYB	ECON	FNCT	NORM	% COND
1	SFR CUST	- 100%	- 2011								
Heated Area: 2870						HX Base Yr 2011					

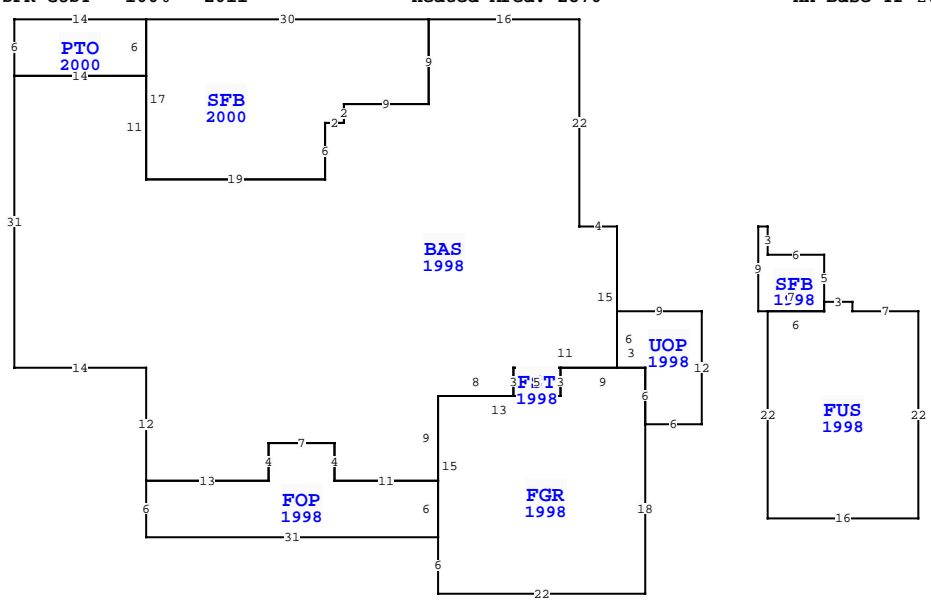

Quality		05 Quality Level 05			
DOR CODE		0100 SINGLE FAMILY			
MAP NUM		MKT AREA 01			
NEIGHBORHOOD/LOC 1072.00					
AREA TYPE	TOTAL GROSS AREA	PCT OF BASE	YEAR	TOT ADJ AREA	SUBAREA MARKET VALUE
BAS	2,138	100	1998	2,138	357,845
FGR	489	55	1998	269	45,024
FOP	214	30	1998	64	10,712
FST	15	55	1998	8	1,339
FUS	355	100	1998	355	59,418
PTO	84	5	2000	4	669
SFB	45	80	1998	36	6,025
SFB	426	80	2000	341	57,074
UOP	90	20	1998	18	3,013
TOTALS	3,856			3,233	541,120

EXTRA FEATURES																	
L N	OB/XF CODE	DESCRIPTION	BLD	CAP	L	W	UNITS	UT	Adj R	ADJ UNIT PRICE	ORIG COND	YEAR ON	YEAR ACTUAL	Q	% COND	OB/XF MKT VALUE	NOTES
1	0810	CONCRETE A	0	100	0	0	776.00	SF	6.50	6.50	100	1998	1998	3	73	3,682	
2	0810	CONCRETE A	0	100	0	0	106.00	SF	6.50	6.50	100	1998	1998	3	73	503	
3	0810	CONCRETE A	0	100	0	0	73.00	SF	6.50	6.50	100	1998	1998	3	73	346	
4	0858	SCULP CONC	0	100	0	0	98.00	SF	13.00	13.00	100	2000	2000	3	93	1,185	

LAND DESCRIPTION																								
TOTAL OB/XF 5,716																								
L N	USE CODE	CLS	LAND USE DESCRIPTION	CAP	R D	LOC ZONE	FRONT	DEPTH	TOT LND UTS	UNIT TYPE	D T	DPH FACT	% COND	TOT ADJ	UNIT PRICE	ADJ UNIT PRICE	LAND VALUE	OTHER ADJUSTMENTS AND NOTES	YEAR	DENSITY	DECL	FRZ	YR	CONSRV
1	000134	C	RES POND	100		R1-G	0.00	0.00	1.00	UT		1.00	1.00	1.05	200,000.00	210,000.00	210,000							

NASSAU COUNTY PROPERTY		PAGE 1 of 1	
VALUATION SUMMARY			
VALUATION BY	STANDARD		
Tax Group: 2	Tax Dist:		
BUILDING MARKET VALUE	541,120		
TOTAL MARKET OB/XF VALUE	5,716		
TOTAL LAND VALUE - MARKET	210,000		
TOTAL MARKET VALUE	756,836		
SOH/AGL Deduction	426,025		
ASSESSED VALUE	330,811		
TOTAL EXEMPTION VALUE	HX HB 50,722		
BASE TAXABLE VALUE	280,089		
TOTAL JUST VALUE	756,836		
NCON VALUE	0		
INCOME VALUE			
PREVIOUS YEAR MKT VALUE	732,442		

PERMIT NUM	DESCRIPTION	AMT	ISSUED
20210745	REPAIR/RRF	0	10/28/2021
20111890	HUR SHUT	18,355	10/20/2011
20110769	ELEC OTHER	100	05/19/2011
B2003952	ADDITION	18,000	09/13/2000
B972452	NEW CONSTR	160,000	01/06/1998

SALES DATA						
OFF RECORD Number	DATE	TYPE INST	Q U	V I	RSN CD	SALE PRICE
1714/0414	11/12/2010	TD	U	I	11	100
GRANTOR: MITCHELL CHESTER C &						
GRANTEE: WILSON ELIZABETH F						
1710/0691	11/12/2010	TD	Q	I	02	391,500
GRANTOR: MITCHELL CHESTER C &						
GRANTEE: WILSON ELIZABETH F						

BUILDING NOTES

BUILDING DIMENSIONS
BAS=[YR=1998] W4 N22 W16 SFB=[YR=2000] W30 PTO=[YR=2000] W14 S6 E14 N6 \$ S17 E19 N6 E2 N2 E9 N9 \$ S9 W9 S2 W2 S6 W19 N11 W14 S31 E14 S12 FOP=[YR=1998] S6 E31 FGR=[YR=1998] S6 E22 N18 UOP=[YR=1998] E6 N12 W9 S6 E3 S6 \$ N6 W9 FST=[YR=1998] W5 S3 E5 N3 \$ S3 W13 S15 \$ N6 W11 N4 W7 S4 W13 \$ E13 N4 E7 S4 E11 N9 E8 N3 E11 N15 \$ PTR= E15 SFB=[YR=1998] E1 S3 E6 S5 FUS=[YR=1998] E3 S1 E7 S22 W16 N22 E6 N1 \$ S1 W7 N9 \$ W15 \$.