

ELEMENT		CD	CONSTRUCTION		
Exterior Wall	05		AVERAGE 80		
Exterior Wall	16		WD FR STUC 20		
Roof Structure	03		GABLE/HIP 100		
Roof Cover	03		COMP SHNGL 100		
Interior Wall	05		DRYWALL 100		
Interior Floor	13		LVT/LAMNT 80		
Interior Floor	11		CLAY TILE 20		
Air Condition	03		CENTRAL 100		
Heating Type	04		AIR DUCTED 100		
Bedrooms			3 100		
Bathrooms			2.5 100		
Frame	02		WOOD FRAME 100		
Stories	2.		2. 100		
Units			0 100		
BUD8 Adjustme	02		DIST FB 100		
Quality	03		Quality Level 03		
DOR CODE	0100		SINGLE FAMILY		
MAP NUM			MKT AREA 01		
NEIGHBORHOOD/LOC			1075.00		
AREA TYPE	TOTAL GROSS AREA	PCT OF BASE	YEAR	TOT ADJ AREA	SUBAREA MARKET VALUE
BAS	1,369	100	1993	1,369	169,673
FEP	195	80	1993	156	19,335
FGR	494	55	1993	272	33,712
FOP	48	30	1993	14	1,735
FOP	84	30	1993	25	3,099
FUS	501	100	1993	501	62,094
PTO	72	5	1993	4	495
TOTALS	2,763			2,341	290,142

MARKET ADJUSTMENTS												
TYPE	MDL	EFF. AREA	TOT ADJ PTS	EFF. BASE RATE	REPL. COST NEW	AYB	EYB	ECON	FNCT	NORM	% COND	
0900	01	2,341	109.5640	144.62	338,555	1988	1995		0	0	14.30	85.70
1 SNGL FAM - 0% - 2023 Heated Area: 1870 HX Base Yr												

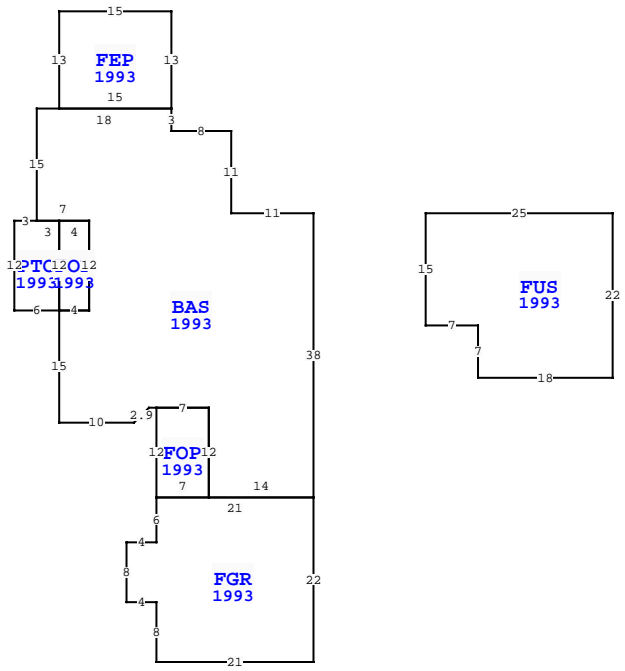

VALUATION BY		STANDARD
Tax Group: 2	Tax Dist:	
BUILDING MARKET VALUE		290,142
TOTAL MARKET OB/XF VALUE		4,994
TOTAL LAND VALUE - MARKET		300,000
TOTAL MARKET VALUE		595,136
SOH/AGL Deduction		4,682
ASSESSED VALUE		590,454
TOTAL EXEMPTION VALUE		0
BASE TAXABLE VALUE		590,454
TOTAL JUST VALUE		595,136
NCON VALUE		0
INCOME VALUE		
PREVIOUS YEAR MKT VALUE		541,578

PERMIT NUM	DESCRIPTION	AMT	ISSUED
B041662	REPAIR/RRF	2,000	09/16/2004
4606-B	N/A	54,750	12/16/1987

SALES DATA						
OFF RECORD Number	DATE	TYPE INST	Q / U	V / I	RSN CD	SALE PRICE
2609/1283	12/12/2022	WD	Q	I	01	595,000
GRANTOR: SISSON MICHAEL R & LI						
GRANTEE: WILSON CLAUDIA & DA						
2298/1344	8/19/2019	WD	Q	I	01	369,000
GRANTOR: HARMON JAMES J & JOHN						
GRANTEE: SISSON MICHAEL R &						

EXTRA FEATURES																
L N	OB/XF CODE	DESCRIPTION	BLD CAP	L	W	UNITS	UT	Adj R	ADJ UNIT PRICE	ORIG COND	YEAR ON	YEAR ACTUAL	Q	% COND	OB/XF MKT VALUE	NOTES
1	0810	CONCRETE A	0	0	42	3	SF	6.50	6.50	100	1988	1988	3	52	426	
2	0811	CONCRETE B	0	0	48	17	SF	5.20	5.20	100	1988	1988	3	52	2,206	
3	0500	FP-PRE FAB	0	0	0	0	UT	3,500.00	3,500.00	100	1988	1988	3	62	2,170	
4	1242	WD DECK A	0	0	12	8	SF	10.00	10.00	100	2003	2003	3	20	192	
TOTALS												2,341	290,142			

BLD DATE		LGL DATE	
04/30/2025	MLU		

BUILDING NOTES	
BUILDING DIMENSIONS	
BAS=[YR=1993] W11 N11 W8 N3 FEP=[YR=1993] N13 W15 S13 E15\$ W18 S15 PTO=[YR=1993] W3 S12 E6 FOP=[YR=1993] E4 N12 W4 S12\$ N12 W3\$ E7 S12 W4 S15 E10 U2 R2 E1 FOP=[YR=1993] S12 FGR=[YR=1993] S6 W4 S8 E4 S8 E21N22 W21\$ E7 N12 W7\$ E7 S12E14 N38\$ PTR=E15 FUS=[YR=1993] E25 S22 W18 N7 W7 N15\$ W15\$.	

LAND DESCRIPTION												TOTAL OB/XF												
L N	USE CODE	CLS	LAND USE DESCRIPTION	CAP	R D	LOC ZONE	FRONT	DEPTH	TOT LND UTS	UNIT TYPE	D T	DPHT FACT	% COND	TOT ADJ	UNIT PRICE	ADJ UNIT PRICE	LAND VALUE	OTHER ADJUSTMENTS AND NOTES	YEAR	DENSITY	DECL	FRZ	YR	CONSRV
1	000100	C	RES	0		R-2	0.00	0.00	1.00	LT		1.00	1.00	1.00	300,000.00	300,000.00	300,000							