

ELEMENT		BUILDING CHARACTERISTICS			
CD	CONSTRUCTION				
05	AVERAGE 80				
16	WD FR STUC 20				
03	GABLE/HIP 100				
03	COMP SHNGL 100				
04	DRYWALL 100				
15	CARPET 90				
11	CLAY TILE 10				
03	CENTRAL 100				
04	AIR DUCTED 100				
	3 100				
	2.5 100				
02	WOOD FRAME 100				
2.	2. 100				
	0 100				
02	DIST FB 100				
03	Quality Level 03				
0100	SINGLE FAMILY				
	MKT AREA		01		
NEIGHBORHOOD/LOC 1075.00					
AREA TYPE	TOTAL GROSS AREA	PCT OF BASE	YEAR	TOT ADJ AREA	SUBAREA MARKET VALUE
BAS	1,398	100	1993	1,398	168,774
FGR	494	55	1993	272	32,838
FOP	48	30	1993	14	1,690
FOP	77	30	1993	23	2,777
FSP	195	40	1993	78	9,417
FUS	501	100	1993	501	60,484
PTO	72	5	1993	4	482
TOTALS	2,785			2,290	276,461

MARKET ADJUSTMENTS											
TYPE	MDL	EFF. AREA	TOT ADJ PTS	EFF. BASE RATE	REPL. COST NEW	AYB	EYB	ECON	FNCT	NORM	% COND
0900	01	2,290	106.7220	140.87	322,592	1988	1995	0	0	14.30	85.70
1 SNGL FAM - 100% - 2021 Heated Area: 1899 HX Base Yr 2021											

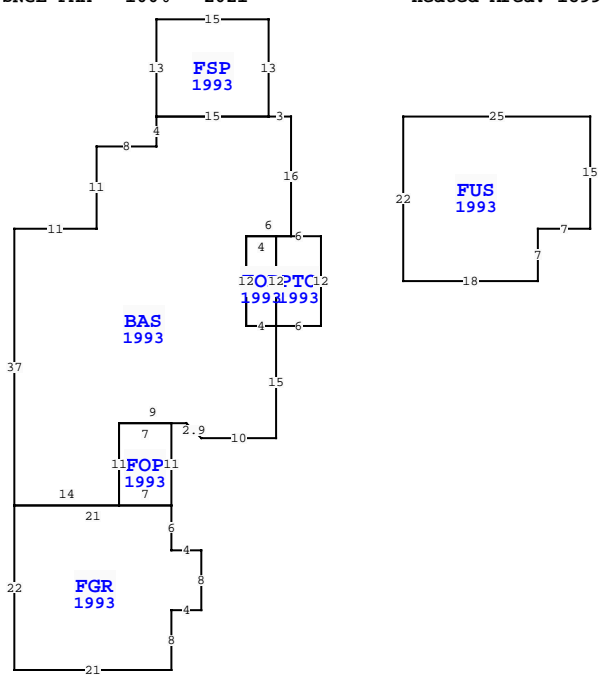

VALUATION SUMMARY		STANDARD
VALUATION BY		STANDARD
Tax Group: 2	Tax Dist:	
BUILDING MARKET VALUE		276,461
TOTAL MARKET OB/XF VALUE		5,069
TOTAL LAND VALUE - MARKET		300,000
TOTAL MARKET VALUE		581,530
SOH/AGL Deduction		161,152
ASSESSED VALUE		420,378
TOTAL EXEMPTION VALUE	HX HB	50,722
BASE TAXABLE VALUE		369,656
TOTAL JUST VALUE		581,530
NCON VALUE		0
INCOME VALUE		
PREVIOUS YEAR MKT VALUE		528,607

PERMIT NUM	DESCRIPTION	AMT	ISSUED
20130731	H/AC	4,500	04/08/2013
B041660	REPAIR/RRF	3,000	09/16/2004
4607-B	N/A	54,750	12/16/1987

SALES DATA						
OFF RECORD Number	DATE	TYPE INST	Q / U	V / I	RSN CD	SALE PRICE
2006/0983	9/30/2015	WD	Q	I	02	270,000
GRANTOR: LAVELLE DONALD L & ME						
GRANTEE: BENDER ZACHARY L &						
0690/0844	10/14/1993	QC	Q	I	01	100
GRANTOR: LAVELLE DONALD & M F						
GRANTEE: LAVELLE DONALD & M						

EXTRA FEATURES																
L N	OB/XF CODE	DESCRIPTION	BLD CAP	L	W	UNITS	UT	Adj R	ADJ UNIT PRICE	ORIG COND	YEAR ON	YEAR ACTUAL	Q	% COND	OB/XF MKT VALUE	NOTES
1	0810	CONCRETE A	0	100	46	17		6.50	6.50	100	1988	1988	3	52	2,643	
2	0812	CONCRETE C	0	100	41	3		4.00	4.00	100	1988	1988	3	52	256	
3	0500	FP-PRE FAB	0	100	0	0		3,500.00	3,500.00	100	1988	1988	3	62	2,170	
TOTALS															5,069	

LAND DESCRIPTION																								
L N	USE CODE	CLS	LAND USE DESCRIPTION	CAP	R D	LOC ZONE	FRONT	DEPTH	TOT LND UTS	UNIT TYPE	D T	DPH FACT	% COND	TOT ADJ	UNIT PRICE	ADJ UNIT PRICE	LAND VALUE	OTHER ADJUSTMENTS AND NOTES	YEAR	DENSITY	DECL	FRZ	YR	CONSRV
1	000100	C	RES	100		R-2	0.00	0.00	1.00	LT		1.00	1.00	1.00	300,000.00	300,000.00	300,000							