

BUILDING CHARACTERISTICS		
ELEMENT	CD	CONSTRUCTION
Exterior Wall	05	AVERAGE 80
Exterior Wall	16	WD FR STUC 20
Roof Structure	03	GABLE/HIP 100
Roof Cover	03	COMP SHNGL 100
Interior Wall	05	DRYWALL 100
Interior Floor	14	CARPET 60
Interior Floor	11	CLAY TILE 40
Air Condition	03	CENTRAL 100
Heating Type	04	AIR DUCTED 100
Bedrooms		3 100
Bathrooms		2 100
Frame	02	WOOD FRAME 100
Stories	2.	2. 100
Units		0 100
Quality	03	Quality Level 03
DOR CODE	0100	SINGLE FAMILY
MAP NUM		MKT AREA 01
NEIGHBORHOOD/LOC		1075.00
AREA TYPE	TOTAL GROSS AREA	PCT OF BASE
BAS	1,351	100
FGR	494	55
FOP	48	30
FOP	84	30
FUS	495	100
PTO	60	5
SFB	182	80
TOTALS	2,714	

MARKET ADJUSTMENTS												
TYPE	MDL	EFF. AREA	TOT ADJ PTS	EFF. BASE RATE	REPL. COST NEW	AYB	EYB	ECON	FNCT	NORM	% COND	
0900	01	2,306	108.5840	143.33	330,519	1990	1995	0	0	14.30	85.70	
1 SNGL FAM - 0% - 0 Heated Area: 1992 HX Base Yr												

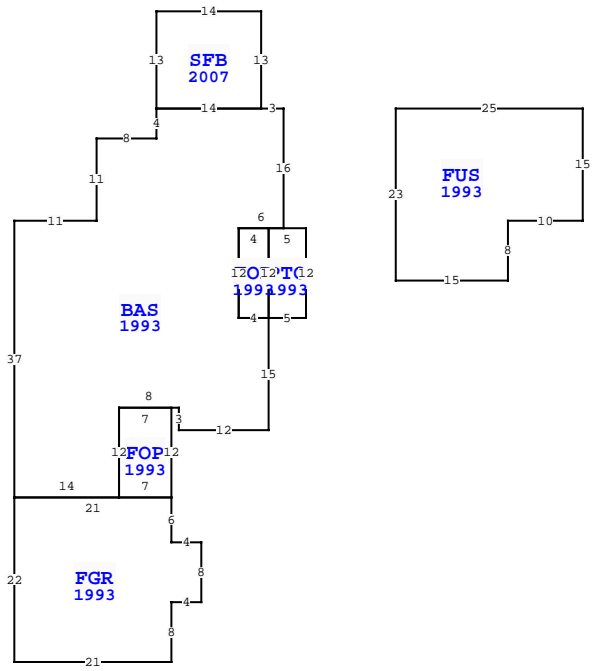

NASSAU COUNTY PROPERTY		PAGE 1 of 1	2
VALUATION SUMMARY			
VALUATION BY			STANDARD
Tax Group: 2	Tax Dist:		
BUILDING MARKET VALUE			283,255
TOTAL MARKET OB/XF VALUE			5,326
TOTAL LAND VALUE - MARKET			300,000
TOTAL MARKET VALUE			588,581
SOH/AGL Deduction			0
ASSESSED VALUE			588,581
TOTAL EXEMPTION VALUE			0
BASE TAXABLE VALUE			588,581
TOTAL JUST VALUE			588,581
NCON VALUE			0
INCOME VALUE			
PREVIOUS YEAR MKT VALUE			535,329

PERMIT NUM	DESCRIPTION	AMT	ISSUED
20052577	REPAIR/RRF	7,000	08/31/2005

SALES DATA						
OFF RECORD Number	DATE	TYPE INST	Q / U	V / I	RSN CD	SALE PRICE
2436/0126	2/17/2021	WD	Q	I	01	400,500
GRANTOR: SHOTTAFAER MARILYN H						
GRANTEE: WHITE MARTIN D & AN						
1071/0227	7/25/2002	WD	Q	I	01	100
GRANTOR: SHOTTAFAER MARILYN H						
GRANTEE: SHOTTAFAER MARILYN H						

EXTRA FEATURES																
L N	OB/XF CODE	DESCRIPTION	BLD CAP	L	W	UNITS	UT	Adj R	ADJ UNIT PRICE	ORIG COND	YEAR ON	YEAR ACTUAL	Q	% COND	OB/XF MKT VALUE	NOTES
1	0500	FP-PRE FAB	0	0	0	1.00	UT	3,500.00	3,500.00	100	1990	1990	3	66	2,310	
2	0812	CONCRETE C	0	0	0	1,323.00	SF	4.00	4.00	100	1990	1990	3	57	3,016	
TOTALS													2,306	283,255		

140 OCEAN RIDGE DR, FERNANDINA BEACH

BLD DATE		LGL DATE	
XF DATE		LAND DATE	04/30/2025
INC DATE		AG DATE	MLU

BUILDING NOTES												
----------------	--	--	--	--	--	--	--	--	--	--	--	--

BUILDING DIMENSIONS												
BAS=[YR=1993] W3 SFB=[YR=2007] N13 W14 S13 E14 \$ W14 S4 W8 S11 W11 S37 FGR=[YR=1993] S22 E21 N8 E4 N8 W4 N6 FOP=[YR=1993] N12 W7 S12 E7 \$ W21 \$ E14 N12 E8 S3 E12 N15 PTO=[YR=1993] E5 N12 W5 S12 \$ FOP=[YR=1993] N12 W4 S12 E4 \$ W4 N12 E6 N16 \$ PTR= E15 FUS=[YR=1993] E25 S15 W10 S8 W15 N23 \$ W15 \$ .												

LAND DESCRIPTION													TOTAL OB/XF												
L N	USE CODE	CLS	LAND USE DESCRIPTION	CAP	R D	LOC ZONE	FRONT	DEPTH	TOT LND UTS	UNIT TYPE	D T	DPH FACT	% COND	TOT ADJ	UNIT PRICE	ADJ UNIT PRICE	LAND VALUE	OTHER ADJUSTMENTS AND NOTES	YEAR	DENSITY	DECL	FRZ	YR	CONSRV	
1	000100	C	RES	0		R-2	0.00	0.00	1.00	LT		1.00	1.00	1.00	300,000.00	300,000.00	300,000								