

BUILDING CHARACTERISTICS	
ELEMENT	CD
Exterior Wall	05 AVERAGE 80
Exterior Wall	16 WD FR STUC 20
Roof Structure	03 GABLE/HIP 100
Roof Cover	03 COMP SHNGL 100
Interior Wall	05 DRYWALL 100
Interior Floor	14 CARPET 70
Interior Floor	13 LVT/LAMNT 30
Air Condition	03 CENTRAL 100
Heating Type	04 AIR DUCTED 100
Bedrooms	3 100
Bathrooms	2 100
Frame	02 WOOD FRAME 100
Stories	2. 2. 100
Units	0 100
BUD8 Adjustme	02 DIST FB 100
Quality	03 Quality Level 03
DOR CODE	0100 SINGLE FAMILY
MAP NUM	MKT AREA 01
NEIGHBORHOOD/LOC	1075.00

MARKET ADJUSTMENTS											
TYPE	MDL	EFF. AREA	TOT ADJ PTS	EFF. BASE RATE	REPL. COST NEW	AYB	EYB	ECON	FNCT	NORM	% COND
0900	01	2,374	104.0760	137.38	326,140	1988	1995	0	0	14.30	85.70

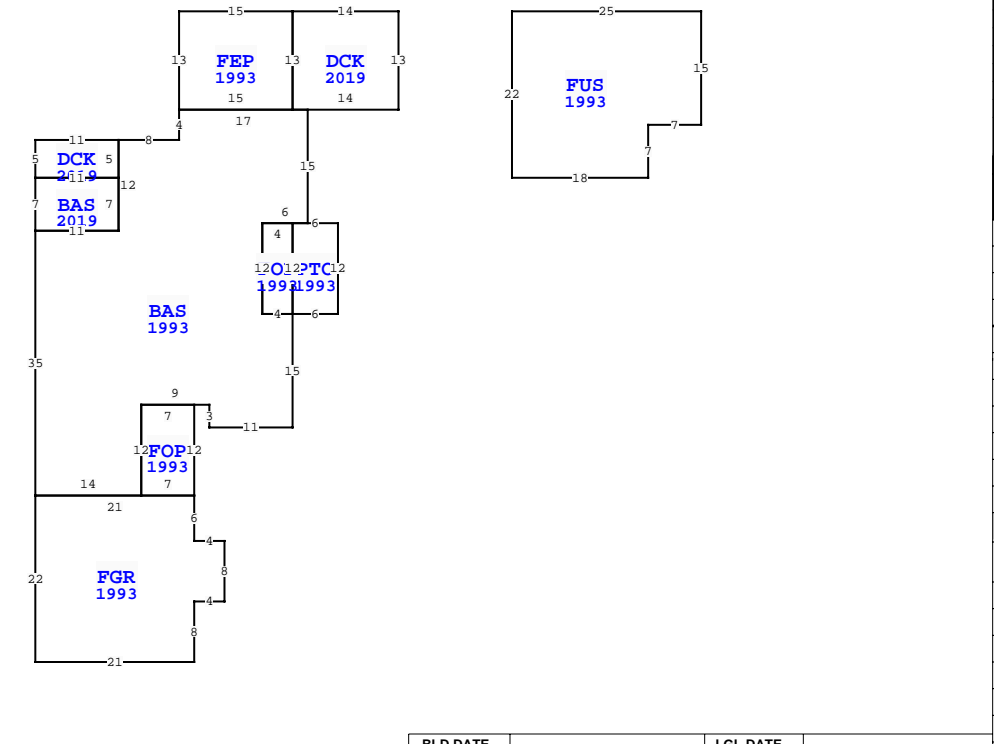

NASSAU COUNTY PROPERTY		PAGE 1 of 1	2
VALUATION SUMMARY			
VALUATION BY	STANDARD		
Tax Group: 2	Tax Dist:		
BUILDING MARKET VALUE			279,502
TOTAL MARKET OB/XF VALUE			6,552
TOTAL LAND VALUE - MARKET			300,000
TOTAL MARKET VALUE			586,054
SOH/AGL Deduction			148,415
ASSESSED VALUE			437,639
TOTAL EXEMPTION VALUE	HX HB		50,722
BASE TAXABLE VALUE			386,917
TOTAL JUST VALUE			586,054
NCON VALUE			0
INCOME VALUE			
PREVIOUS YEAR MKT VALUE			538,027

AREA TYPE	TOTAL GROSS AREA	PCT OF BASE	YEAR	TOT ADJ AREA	SUBAREA MARKET VALUE
BAS	1,301	100	1993	1,301	153,172
BAS	77	100	2019	77	9,065
DCK	55	10	2019	6	706
DCK	182	10	2019	18	2,119
FEP	195	80	1993	156	18,366
FGR	494	55	1993	272	32,024
FOP	48	30	1993	14	1,648
FOP	84	30	1993	25	2,944
FUS	501	100	1993	501	58,985
PTO	72	5	1993	4	471
TOTALS	3,009			2,374	279,502

PERMIT NUM	DESCRIPTION	AMT	ISSUED
20190192	ADD 66SF	0	03/11/2019
20042193	REPAIR/RRF	3,000	11/22/2004
B0012127	ADDITION	6,000	09/27/2001
4853	NEW CONSTR	54,750	05/20/1988

SALES DATA						
OFF RECORD Number	DATE	TYPE INST	Q / U	V / I	RSN CD	SALE PRICE
2128/0353	6/19/2017	WD	Q	I	01	388,500
GRANTOR: VERRIER TRACEY						
GRANTEE: ARPIN RUSSELL F & A						
2084/1906	11/02/2016	SW	U	I	12	308,800
GRANTOR: NATIONSTAR HECM ACQUI						
GRANTEE: VERRIER TRACEY						

L N	OB/XF CODE	DESCRIPTION	BLD CAP	L	W	UNITS	UT	Adj R	ADJ UNIT PRICE	ORIG COND	YEAR ON	YEAR ACTUAL	Q	% COND	OB/XF MKT VALUE	NOTES
1	0811	CONCRETE B	0	100	46	17	SF	5.20	5.20	100	1988	1988	3	52	2,115	
2	0810	CONCRETE A	0	100	44	3	SF	6.50	6.50	100	1988	1988	3	52	446	
3	0500	FP-PRE FAB	0	100	0	0	UT	3,500.00	3,500.00	100	1988	1988	3	62	2,170	
4	0811	CONCRETE B	0	100	0	0	SF	5.20	5.20	100	1995	1995	3	68	1,821	
<b>TOTAL OB/XF 6,552</b>																

BLD DATE		LGL DATE	
XF DATE	INC DATE	LAND DATE	AG DATE
		04/30/2025	MLU

BUILDING NOTES	
DCK=[YR=2019] W14 FEP=[YR=1993] W15 S13 BAS=[YR=1993] S4 W8 DCK=[YR=2019] W11S5 BAS=[YR=2019] S7 E11 N7 W11\$ E11 N5\$ S12 W11 S35 FGR=[YR=1993] S22 E21 N8 E4 N8 W4 N6FOP=[YR=1993] N12 W7 S12 E7\$ W21\$ E14 N12 E9 S3 E11N15 PTO=[YR=1993] E6 N12 W6 FOP=[YR=1993] W4 S12 E4 N12\$ S12\$ W4 N12 E6 N15 W17\$ E15 N13\$ S13 E14 N13\$ PTR= E15 FUS=[YR=1993] E25 S15 W7 S7 W18 N22\$ W15\$.	

LAND DESCRIPTION		TOTAL OB/XF 6,552																						
L N	USE CODE	CLS	LAND USE DESCRIPTION	CAP	R D	LOC ZONE	FRONT	DEPTH	TOT LND UTS	UNIT TYPE	D T	DPH FACT	% COND	TOT ADJ	UNIT PRICE	ADJ UNIT PRICE	LAND VALUE	OTHER ADJUSTMENTS AND NOTES	YEAR	DENSITY	DECL	FRZ	YR	CONSRV
1	000134	C	RES POND	100		R-2	0.00	0.00	1.00	LT		1.00	1.00	1.00	300,000.00	300,000.00	300,000							