

| BUILDING CHARACTERISTICS | | |
|--------------------------|-----|----------------|
| ELEMENT | CD | CONSTRUCTION |
| Exterior Wall | 31 | HARDIE BRD 100 |
| Roof Structur | 03 | GABLE/HIP 100 |
| Roof Cover | 13 | STAND SEAM 100 |
| Interior Wall | 05 | DRYWALL 100 |
| Interior Floor | 11 | CLAY TILE 100 |
| Interior Finish | NEW | N/A 0 |
| Air Condition | 03 | CENTRAL 100 |
| Heating Type | 04 | AIR DUCTED 100 |
| Bedrooms | | 4 100 |
| Bathrooms | | 5 100 |
| Frame | 02 | WOOD FRAME 100 |
| Stories | 2. | 2. 100 |
| Units | | 0 100 |

| MARKET ADJUSTMENTS | | | | | | | | | | | |
|--------------------|----------|-----------|-------------|----------------|----------------|-----------------|-----|------|------|------|--------|
| TYPE | MDL | EFF. AREA | TOT ADJ PTS | EFF. BASE RATE | REPL. COST NEW | AYB | EYB | ECON | FNCT | NORM | % COND |
| 1 | SFR CUST | - 100% | - 2024 | | | | | | | | |
| Heated Area: 3779 | | | | | | HX Base Yr 2024 | | | | | |

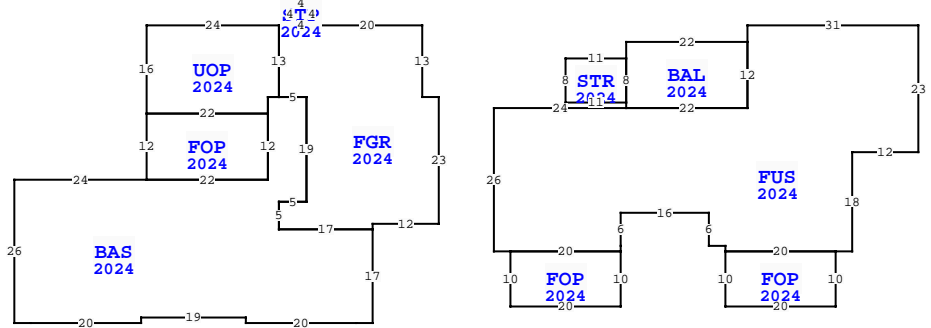

| Quality | 04 | Quality Level 04 | | | |
|------------------|------------------|------------------|------|--------------|----------------------|
| DOR CODE | 0100 | SINGLE FAMILY | | | |
| MAP NUM | | MKT AREA 01 | | | |
| NEIGHBORHOOD/LOC | 1057.00 | | | | |
| AREA TYPE | TOTAL GROSS AREA | PCT OF BASE | YEAR | TOT ADJ AREA | SUBAREA MARKET VALUE |
| BAL | 264 | 15 | 2024 | 40 | 7,533 |
| BAS | 1,643 | 100 | 2024 | 1,643 | 309,426 |
| FGR | 927 | 55 | 2024 | 510 | 96,048 |
| FOP | 200 | 30 | 2024 | 60 | 11,300 |
| FOP | 200 | 30 | 2024 | 60 | 11,300 |
| FOP | 264 | 30 | 2024 | 79 | 14,878 |
| FUS | 2,136 | 100 | 2024 | 2,136 | 402,273 |
| STP | 16 | 10 | 2024 | 2 | 377 |
| STR | 88 | 10 | 2024 | 9 | 1,695 |
| UOP | 378 | 20 | 2024 | 76 | 14,313 |
| TOTALS | 6,116 | | | 4,615 | 869,143 |

1507 S FLETCHER AVE, FERNANDINA BEACH

| | | | |
|----------|-----------|------------|-----|
| BLD DATE | LGL DATE | 05/07/2025 | MLU |
| XF DATE | LAND DATE | | |
| INC DATE | AG DATE | | |

| EXTRA FEATURES | | | | | | | | | | | | | | | | | |
|----------------|------------|-------------|-----|-----|---|---|----------|----|--------|----------------|-----------|---------|-------------|---|--------|-----------------|-------|
| L N | OB/XF CODE | DESCRIPTION | BLD | CAP | L | W | UNITS | UT | Adj R | ADJ UNIT PRICE | ORIG COND | YEAR ON | YEAR ACTUAL | Q | % COND | OB/XF MKT VALUE | NOTES |
| 1 | 0855 | CONC PAVER | 0 | 100 | 0 | 0 | 3,549.00 | SF | 10.00 | 10.00 | 100 | 2024 | 2023 | | 100 | 35,490 | |
| 2 | 0861 | POOL GUNIT | 0 | 100 | 0 | 0 | 377.00 | SF | 85.00 | 85.00 | 100 | 2024 | 2023 | | 98 | 31,404 | |
| 3 | 0462 | ST/AL FNC | 0 | 100 | 0 | 0 | 138.00 | SF | 10.00 | 10.00 | 100 | 2024 | 2023 | | 98 | 1,352 | |
| 4 | 0463 | FENCE GATE | 0 | 100 | 0 | 0 | 2.00 | UT | 300.00 | 300.00 | 100 | 2024 | 2023 | | 99 | 594 | |
| 5 | 0855 | CONC PAVER | 0 | 100 | 0 | 0 | 1,500.00 | SF | 10.00 | 10.00 | 100 | 2025 | 2024 | | 100 | 15,000 | |
| 6 | 0476 | VF 6 SBPL | 0 | 100 | 0 | 0 | 90.00 | LF | 32.00 | 32.00 | 100 | 2025 | 2024 | | 100 | 2,880 | |
| 7 | 0475 | VF 4 SBPL | 0 | 100 | 0 | 0 | 36.00 | LF | 14.00 | 14.00 | 100 | 2025 | 2024 | | 100 | 504 | |

TOTAL OB/XF 87,224

| LAND DESCRIPTION | | | | | | | | | | | | | | | | | | | | | | | | |
|------------------|----------|-----|----------------------|-----|------|----------|--------|--------|-------------|-----------|-----|-----------|--------|---------|------------|----------------|------------|-----------------------------|------|---------|------|-----|----|--------|
| L N | USE CODE | CLS | LAND USE DESCRIPTION | CAP | R D | LOC ZONE | FRONT | DEPTH | TOT LND UTS | UNIT TYPE | D T | DPTH FACT | % COND | TOT ADJ | UNIT PRICE | ADJ UNIT PRICE | LAND VALUE | OTHER ADJUSTMENTS AND NOTES | YEAR | DENSITY | DECL | FRZ | YR | CONSRV |
| 1 | 000100 | C | RES | 100 | 0006 | R-1 | 144.00 | 125.00 | 144.00 | FF | | 1.00 | 1.00 | 0.60 | 7,500.00 | 4,500.00 | 648,000 | | | | | | | |

| NASSAU COUNTY PROPERTY | | PAGE 1 of 1 | 2 |
|---------------------------|-----------|-------------|---|
| VALUATION SUMMARY | | | |
| VALUATION BY | STANDARD | | |
| Tax Group: 2 | Tax Dist: | | |
| BUILDING MARKET VALUE | 869,143 | | |
| TOTAL MARKET OB/XF VALUE | 87,224 | | |
| TOTAL LAND VALUE - MARKET | 648,000 | | |
| TOTAL MARKET VALUE | 1,604,367 | | |
| SOH/AGL Deduction | 96,412 | | |
| ASSESSED VALUE | 1,507,955 | | |
| TOTAL EXEMPTION VALUE | HX HB | 50,722 | |
| BASE TAXABLE VALUE | 1,457,233 | | |
| TOTAL JUST VALUE | 1,604,367 | | |
| NCON VALUE | 18,384 | | |
| INCOME VALUE | | | |
| PREVIOUS YEAR MKT VALUE | 1,447,591 | | |

| PERMIT NUM | DESCRIPTION | AMT | ISSUED |
|-------------|-------------|-------|------------|
| 20200018 | DEMOLITION | 0 | 07/22/2020 |
| 20090118 | H/AC | 0 | 01/27/2009 |
| 6772 | REPAIR/RRF | 2,400 | 10/14/1991 |
| BLDR-2021-1 | | | |

| SALES DATA | | | | | | |
|--------------------------------|-----------|-----------|-----|-----|--------|------------|
| OFF RECORD Number | DATE | TYPE INST | Q U | V I | RSN CD | SALE PRICE |
| 2773/1445 | 3/11/2025 | QC | U | I | 11 | 100 |
| GRANTOR: BEACH THOMAS M | | | | | | |
| GRANTEE: BEACH THOMAS M & FE | | | | | | |
| 2374/1306 | 7/08/2020 | WD | U | I | 37 | 400,000 |
| GRANTOR: RIO LAND & INVESTMENT | | | | | | |
| GRANTEE: BEACH THOMAS M & KA | | | | | | |

| BUILDING NOTES | | | | | | | | | | | | |
|----------------|--|--|--|--|--|--|--|--|--|--|--|--|
|----------------|--|--|--|--|--|--|--|--|--|--|--|--|

| BUILDING DIMENSIONS | | | | | | | | | | | | |
|---|--|--|--|--|--|--|--|--|--|--|--|--|
| FGR=[YR=2024;ORIG=70,0] W20 W4 W2 S13 E5 S19 W5 S5 E17 N1 E12 N23 W3 N13 \$ | | | | | | | | | | | | |
| STP=[YR=2024;ORIG=46,-4] E4 S4 W4 N4 \$ | | | | | | | | | | | | |
| BAS=[YR=2024;ORIG=49,13] W5 W2 S3 S12 W22 W24 S26 E3 E20 N1 E19 S1 E20 E3 N17 W17 N5 E5 N19 \$ | | | | | | | | | | | | |
| FOP=[YR=2024;ORIG=42,16] W22 S12 E22 N12 \$ | | | | | | | | | | | | |
| UOP=[YR=2024;ORIG=44,0] W24 S16 E22 N3 E2 N13 \$ | | | | | | | | | | | | |
| FUS=[YR=2024;ORIG=160,0] W31 S3 S12 W22 W24 S26 E3 E20 N1 N6 E16 S6 E3 S1 E20 E3 N18 E12 N23 \$ | | | | | | | | | | | | |
| BAL=[YR=2024;ORIG=129,3] W22 S3 S8 S1 E22 N12 \$ | | | | | | | | | | | | |
| STR=[YR=2024;ORIG=107,6] W11 S8 E11 N8 \$ | | | | | | | | | | | | |
| FOP=[YR=2024;ORIG=125,41] E20 S10 W20 N10 \$ | | | | | | | | | | | | |