

BUILDING CHARACTERISTICS		
ELEMENT	CD	CONSTRUCTION
Exterior Wall	10	ABOVE AVG 60
Exterior Wall	17	CB STUCCO 40
Roof Structure	03	GABLE/HIP 100
Roof Cover	13	STAND SEAM 100
Interior Wall	05	DRYWALL 100
Interior Floor	11	CLAY TILE 50
Interior Floor	12	HARDWOOD 50
Air Condition	03	CENTRAL 100
Heating Type	04	AIR DUCTED 100
Bedrooms		4 100
Bathrooms		3.5 100
Frame	04	REIN CONC 100
Stories	3.	3. 100
Units		0 100

MARKET ADJUSTMENTS											
TYPE	MDL	EFF. AREA	TOT ADJ PTS	EFF. BASE RATE	REPL. COST NEW	AYB	EYB	ECON	FNCT	NORM	% COND
0500	11	3,981	158.1174	249.83	994,573	2020	2020	0	0	1.70	98.30
1 SFR CUST - 100% - 2024 Heated Area: 3502 HX Base Yr 2024											

NASSAU COUNTY PROPERTY			
VALUATION SUMMARY			PAGE 1 of 1
VALUATION BY		STANDARD	
Tax Group: 2		Tax Dist:	
BUILDING MARKET VALUE		977,665	
TOTAL MARKET OB/XF VALUE		67,602	
TOTAL LAND VALUE - MARKET		1,140,000	
TOTAL MARKET VALUE		2,185,267	
SOH/AGL Deduction		135,622	
ASSESSED VALUE		2,049,645	
TOTAL EXEMPTION VALUE		HX HB 50,722	
BASE TAXABLE VALUE		1,998,923	
TOTAL JUST VALUE		2,185,267	
NCON VALUE		0	
INCOME VALUE			
PREVIOUS YEAR MKT VALUE		1,991,880	

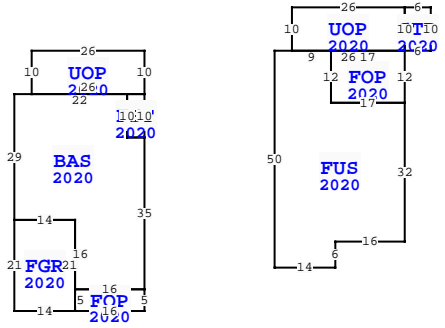
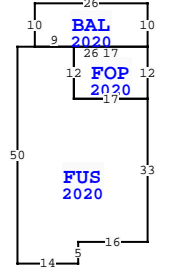

Quality	06	Quality Level 06			
DOR CODE	0100	SINGLE FAMILY			
MAP NUM		MKT AREA 01			
NEIGHBORHOOD/LOC	1052.00				
AREA TYPE	TOTAL GROSS AREA	PCT OF BASE	YEAR	TOT ADJ AREA	SUBAREA MARKET VALUE
BAL	260	15	2020	39	9,577
BAS	1,086	100	2020	1,086	266,703
FGR	294	55	2020	162	39,784
FOP	80	30	2020	24	5,894
FOP	204	30	2020	61	14,981
FOP	204	30	2020	61	14,981
FST	40	55	2020	22	5,403
FUS	1,200	100	2020	1,200	294,699
FUS	1,216	100	2020	1,216	298,629
STR	60	10	2020	6	1,474
TOTALS	5,164			3,981	977,665

** This building has 12 Sub-Areas

BLD DATE	LGL DATE	05/07/2025	MLU
XF DATE	LAND DATE		
INC DATE	AG DATE		

PERMIT NUM	DESCRIPTION	AMT	ISSUED
20190300	CO ISSUED	0	12/16/2020
20190561	SWIM POOL	0	09/25/2019
20190300	NEW CONSTR	0	06/24/2019
20190054	DEMOLITION	0	01/07/2019
20170065	MTLRF	0	01/18/2017
E0012690	TEMP POLE	3,000	12/21/2001

SALES DATA						
OFF RECORD Number	DATE	TYPE INST	Q / U	V / I	RSN CD	SALE PRICE
1236/0322	6/07/2004	WD	Q	I		1,300,000
GRANTOR: MCGROGAN PATRICK A						
GRANTEE: JONES CAREY B & CAR						
1022/1879	12/05/2001	WD	Q	I		525,000
GRANTOR: MCGROGAN CONSULTING C						
GRANTEE: MCGROGAN PATRICK A						

EXTRA FEATURES																
L N	OB/XF CODE	DESCRIPTION	BLD CAP	L	W	UNITS	UT	Adj R	ADJ UNIT PRICE	ORIG COND	YEAR ON	YEAR ACTUAL	Q	% COND	OB/XF MKT VALUE	NOTES
1	0855	CONC PAVER	0	100	0	1,234.00	SF	10.00	10.00	100	2020	2020	3	98	12,093	
2	0409	ELEVATOR R	0	100	0	1.00	UT	12,240.00	12,240.00	100	2020	2020	3	100	12,240	
3	0861	POOL GUNIT	0	100	0	432.00	SF	85.00	85.00	100	2020	2020	3	90	33,048	
4	0857	SANDSTONE/	0	100	0	468.00	SF	16.00	16.00	100	2020	2020	3	99	7,413	
5	0462	ST/AL FNC	0	100	0	312.00	SF	10.00	10.00	100	2020	2020	3	90	2,808	

BUILDING NOTES	

BUILDING DIMENSIONS	
UOP=[YR=2020] W26 S10 BAS=[YR=2020] W4 S29 FGR=[YR=2020] S21 E14 FOP=[YR=2020] E16 N5 W16 S5 \$ N21 W14 \$ E14 S16 E16 N35 FST=[YR=2020] N10 W4 S10 E4 \$ W4 N10 W22 \$ E26 N10 \$PTR= E30 FUS=[YR=2020] E4 UOP=[YR=2020] N10 E26 STR=[YR=2020] E6 S10 W6 N10 \$ S10 FOP=[YR=2020] S12 W17 N12 E17 \$W26 \$ E9 S12 E17 S32 W16 S6 W14 N50 \$ W30\$ PTR= N30 FUS=[YR=2020] N50 E4 BAL=[YR=2020] N10 E26 S10 FOP=[YR=2020] S12 W17 N12 E17 \$ W26 \$ E9 S12 E17 S33 W16 S5 W14 \$ S30\$.	

LAND DESCRIPTION																								
TOTAL OB/XF 67,602																								
L N	USE CODE	CLS	LAND USE DESCRIPTION	CAP	R D	LOC ZONE	FRONT	DEPTH	TOT LND UTS	UNIT TYPE	D T	DPH FACT	% COND	TOT ADJ	UNIT PRICE	ADJ UNIT PRICE	LAND VALUE	OTHER ADJUSTMENTS AND NOTES	YEAR	DENSITY	DECL	FRZ	YR	CONSRV
1	000120	C	RES OCEAN	100		R-2	50.00	250.00	50.00	FF		1.00	1.00	1.20	19,000.00	22,800.00	1,140,000							