

BUILDING CHARACTERISTICS		CONSTRUCTION	
ELEMENT	CD		
Exterior Wall	10	ABOVE AVG	100
Roof Structur	08	IRREGULAR	100
Roof Cover	03	COMP SHNGL	100
Interior Wall	05	DRYWALL	100
Interior Floo	14	CARPET	70
Interior Floo	15	HARDTILE	30
Air Condition	03	CENTRAL	100
Heating Type	04	AIR DUCTED	100
Bedrooms		3	100
Bathrooms		2	100
Frame	02	WOOD FRAME	100
Stories	1.	1.	100
Units		0	100
Occupancy	00	NONE	100
Quality	03	Quality Level	03
DOR CODE	0100	SINGLE FAMILY	
MAP NUM		MKT AREA	01
NEIGHBORHOOD/LOC	1031.00		
AREA TYPE	TOTAL GROSS AREA	PCT OF BASE	YEAR
BAS	2,053	100	2004
FDG	400	60	2004
FOP	247	30	2004
FSP	300	40	2005
PTO	233	5	2004
TOTALS	3,233		

MARKET ADJUSTMENTS											
TYPE	MDL	EFF. AREA	TOT ADJ PTS	EFF. BASE RATE	REPL. COST NEW	AYB	EYB	ECON	FNCT	NORM	% COND
1	SFR CUST	- 100%	- 2007								
Heated Area: 2053					HX Base Yr 2007						

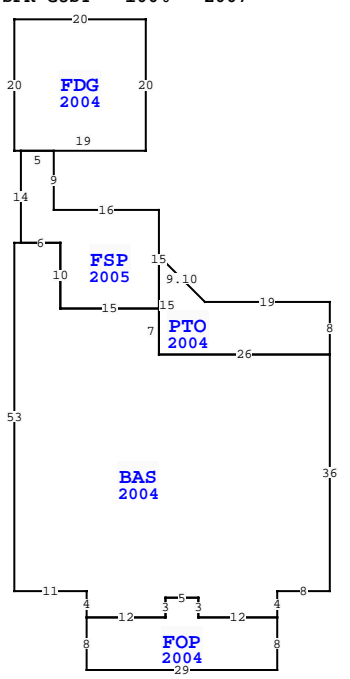

NASSAU COUNTY PROPERTY		PAGE 1 of 1	2
VALUATION SUMMARY			
VALUATION BY			STANDARD
Tax Group: 2	Tax Dist:		
BUILDING MARKET VALUE			491,852
TOTAL MARKET OB/XF VALUE			39,097
TOTAL LAND VALUE - MARKET			300,000
TOTAL MARKET VALUE			830,949
SOH/AGL Deduction			471,767
ASSESSED VALUE			359,182
TOTAL EXEMPTION VALUE	HX HB		50,722
BASE TAXABLE VALUE			308,460
TOTAL JUST VALUE			830,949
NCON VALUE			0
INCOME VALUE			
PREVIOUS YEAR MKT VALUE			749,721

PERMIT NUM	DESCRIPTION	AMT	ISSUED
20190525	SWIM POOL	0	10/02/2019
20051147	XFOB	4,000	01/28/2005
20042337	OTHER	1,000	12/13/2004
20041183	NEW CONSTR	209,000	06/28/2004

SALES DATA						
OFF RECORD Number	DATE	TYPE INST	Q / U	V / I	RSN CD	SALE PRICE
2800/664	7/11/2025	WD	U	I	11	100
GRANTOR: DONINI JOSEPH V REVOC						
GRANTEE: DONINI JOSEPH V						
1994/0803	7/29/2015	WD	U	I	11	100
GRANTOR: DONINI JOSEPH V						
GRANTEE: DONINI JOSEPH V REV						

EXTRA FEATURES															BLD DATE	LGL DATE		
L N	OB/XF CODE	DESCRIPTION	BLD CAP	L	W	UNITS	UT	Adj R	ADJ UNIT PRICE	ORIG COND	YEAR ON	YEAR ACTUAL	Q	% COND	OB/XF MKT VALUE	NOTES		
1	0819	CONC 12"	0	100	2	5			9.50	100	2004	2004	3	83	79			
2	0810	CONCRETE A	0	100	13	5			6.50	100	2004	2004	3	83	351			
3	0810	CONCRETE A	0	100	4	4			6.50	100	2004	2004	3	83	86			
4	0810	CONCRETE A	0	100	0	0			6.50	100	2004	2004	3	83	4,478			
5	0470	VNYL GATE	0	100	0	0			300.00	100	2004	2004	3	61	183			
6	0476	VF 6 SBPL	0	100	0	0			32.00	100	2004	2004	3	61	1,386			
7	0861	POOL GUNIT	0	100	0	0			85.00	100	2020	2020	3	90	26,928			
8	0855	CONC PAVER	0	100	0	0			10.00	100	2020	2020	3	98	5,606			
TOTALS															39,097			

LAND DESCRIPTION															TOTAL OB/XF									
L N	USE CODE	CLS	LAND USE DESCRIPTION	CAP	R D	LOC ZONE	FRONT	DEPTH	TOT LND UTS	UNIT TYPE	D T	DPH FACT	% COND	TOT ADJ	UNIT PRICE	ADJ UNIT PRICE	LAND VALUE	OTHER ADJUSTMENTS AND NOTES	YEAR	DENSITY	DECL	FRZ	YR	CONSRV
1	000100	C	RES	100	0003	R-2	0.00	0.00	60.00	FF		1.00	1.00	1.00	5,000.00	5,000.00	300,000							