

| BUILDING CHARACTERISTICS | |
|--------------------------|-------------------|
| ELEMENT | CD CONSTRUCTION |
| Exterior Wall | 10 ABOVE AVG 100 |
| Roof Structur | 08 IRREGULAR 100 |
| Roof Cover | 03 COMP SHNGL 100 |
| Interior Wall | 05 DRYWALL 100 |
| Interior Floo | 14 CARPET 60 |
| Interior Floo | 15 HARDTILE 40 |
| Air Condition | 03 CENTRAL 100 |
| Heating Type | 04 AIR DUCTED 100 |
| Bedrooms | 5 100 |
| Bathrooms | 5 100 |
| Frame | 02 WOOD FRAME 100 |
| Stories | 1.5 100 |
| Units | 0 100 |
| Occupancy | 00 NONE 100 |

| MARKET ADJUSTMENTS | | | | | | | | | | | | |
|--------------------|-----|-----------|-------------|----------------|----------------|------|------|------|------|------|--------|-------|
| TYPE | MDL | EFF. AREA | TOT ADJ PTS | EFF. BASE RATE | REPL. COST NEW | AYB | EYB | ECON | FNCT | NORM | % COND | |
| 0500 | 11 | 3,992 | 135.1026 | 213.46 | 852,132 | 2007 | 2007 | 0 | 0 | 0 | 8.00 | 92.00 |

| NASSAU COUNTY PROPERTY | | PAGE 1 of 1 | 2 |
|---------------------------|-----------|-------------|-----------|
| VALUATION SUMMARY | | | |
| VALUATION BY | STANDARD | | |
| Tax Group: 2 | Tax Dist: | | |
| BUILDING MARKET VALUE | | | 783,961 |
| TOTAL MARKET OB/XF VALUE | | | 33,656 |
| TOTAL LAND VALUE - MARKET | | | 275,000 |
| TOTAL MARKET VALUE | | | 1,092,617 |
| SOH/AGL Deduction | | | 451,151 |
| ASSESSED VALUE | | | 641,466 |
| TOTAL EXEMPTION VALUE | HX HB | | 50,722 |
| BASE TAXABLE VALUE | | | 590,744 |
| TOTAL JUST VALUE | | | 1,092,617 |
| NCON VALUE | | | 0 |
| INCOME VALUE | | | |
| PREVIOUS YEAR MKT VALUE | | | 1,003,244 |

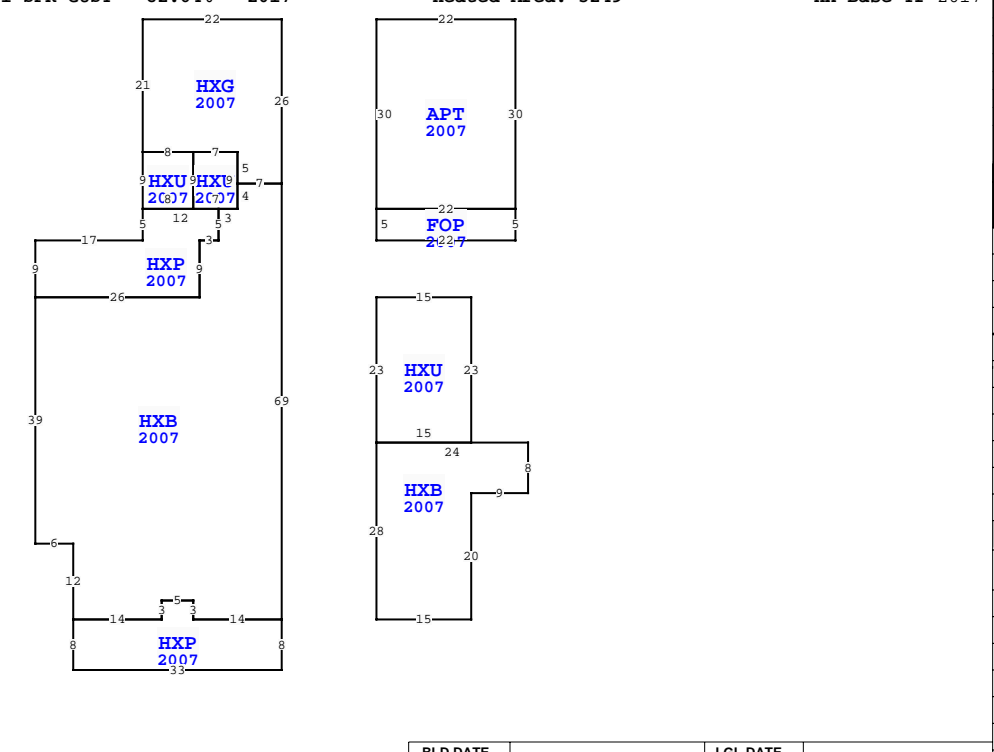

| Quality | | 03 Quality Level 03 | | | |
|------------------|------------------|---------------------|------|--------------|----------------------|
| DOR CODE | | 0100 SINGLE FAMILY | | | |
| MAP NUM | | MKT AREA 01 | | | |
| NEIGHBORHOOD/LOC | | 1031.00 | | | |
| AREA TYPE | TOTAL GROSS AREA | PCT OF BASE | YEAR | TOT ADJ AREA | SUBAREA MARKET VALUE |
| APT | 660 | 100 | 2007 | 660 | 129,613 |
| FOP | 110 | 30 | 2007 | 33 | 6,480 |
| HXB | 492 | 100 | 2007 | 492 | 96,620 |
| HXB | 2,097 | 100 | 2007 | 2,097 | 411,816 |
| HXG | 497 | 55 | 2007 | 273 | 53,613 |
| HXP | 279 | 30 | 2007 | 84 | 16,497 |
| HXP | 294 | 30 | 2007 | 88 | 17,281 |
| HXU | 63 | 55 | 2007 | 35 | 6,873 |
| HXU | 72 | 55 | 2007 | 40 | 7,855 |
| HXU | 345 | 55 | 2007 | 190 | 37,312 |
| TOTALS | 4,909 | | | 3,992 | 783,961 |

| PERMIT NUM | DESCRIPTION | AMT | ISSUED |
|------------|-------------|--------|------------|
| 20140593 | SWIM POOL | 31,650 | 03/27/2014 |
| 20070107 | OTHER | 500 | 01/24/2007 |
| 20070010 | ELEC OTHER | 3,080 | 01/03/2007 |
| 20070011 | H/AC | 5,540 | 01/03/2007 |
| 20062344 | NEW CONSTR | 28,500 | 10/17/2006 |
| 20062345 | GAS | 300 | 10/17/2006 |

| SALES DATA | | | | | | |
|--------------------------------|-----------|-----------|-------|-------|--------|------------|
| OFF RECORD Number | DATE | TYPE INST | Q / U | V / I | RSN CD | SALE PRICE |
| 2055/1235 | 6/28/2016 | WD | Q | I | 01 | 595,000 |
| GRANTOR: BREEN KEVIN J & MARGA | | | | | | |
| GRANTEE: DUFFY ROBERT P & MA | | | | | | |
| 1903/1432 | 2/18/2014 | WD | Q | I | 02 | 460,000 |
| GRANTOR: CHAPMAN ELIZABETH LIT | | | | | | |
| GRANTEE: BREEN KEVIN J & MAR | | | | | | |

| EXTRA FEATURES | | | | | | | | | | | | | | | | |
|----------------|------------|-------------|---------|-----|----|-------|----|--------|----------------|-----------|---------|-------------|---|--------|-----------------|-------|
| L N | OB/XF CODE | DESCRIPTION | BLD CAP | L | W | UNITS | UT | Adj R | ADJ UNIT PRICE | ORIG COND | YEAR ON | YEAR ACTUAL | Q | % COND | OB/XF MKT VALUE | NOTES |
| 1 | 0810 | CONCRETE A | 0 | 100 | 11 | 14 | SF | 6.50 | 6.50 | 100 | 2007 | 2007 | 3 | 87 | 871 | |
| 2 | 0825 | BRICK | 0 | 100 | 27 | 6 | SF | 12.50 | 12.50 | 100 | 2007 | 2007 | 3 | 96 | 1,944 | |
| 3 | 0861 | POOL GUNIT | 0 | 100 | 0 | 0 | SF | 85.00 | 85.00 | 100 | 2014 | 2014 | 3 | 71 | 19,553 | |
| 4 | 0855 | CONC PAVER | 0 | 100 | 0 | 0 | SF | 7.00 | 7.00 | 100 | 2014 | 2014 | 3 | 94 | 6,725 | |
| 5 | 0470 | VNYL GATE | 0 | 100 | 0 | 0 | UT | 300.00 | 300.00 | 100 | 2014 | 2014 | 3 | 85 | 255 | |
| 6 | 0476 | VF 6 SBPL | 0 | 100 | 0 | 0 | LF | 32.00 | 32.00 | 100 | 2014 | 2014 | 3 | 85 | 3,101 | |
| 7 | 1127 | BRICK 8" | 0 | 100 | 0 | 0 | SF | 11.00 | 11.00 | 100 | 2014 | 2014 | 3 | 98 | 1,207 | |

| TOTAL OB/XF | | | | | | | | | | | | | 33,656 | | | | | | | | | | | |
|-------------|----------|-----|----------------------|-----|------|----------|-------|-------|-------------|-----------|-----|-----------|--------|---------|------------|----------------|------------|-----------------------------|------|---------|------|-----|----|--------|
| L N | USE CODE | CLS | LAND USE DESCRIPTION | CAP | R D | LOC ZONE | FRONT | DEPTH | TOT LND UTS | UNIT TYPE | D T | DPTH FACT | % COND | TOT ADJ | UNIT PRICE | ADJ UNIT PRICE | LAND VALUE | OTHER ADJUSTMENTS AND NOTES | YEAR | DENSITY | DECL | FRZ | YR | CONSRV |
| 1 | 000100 | C | RES | 100 | 0003 | R-2 | 0.00 | 0.00 | 55.00 | FF | | 1.00 | 1.00 | 1.00 | 5,000.00 | 5,000.00 | 275,000 | | | | | | | |

| LAND DESCRIPTION | | TOTAL OB/XF 33,656 | | | | | | | | | | | | | | | | | | | | | | |
|------------------|----------|--------------------|----------------------|-----|------|----------|-------|-------|-------------|-----------|-----|-----------|--------|---------|------------|----------------|------------|-----------------------------|------|---------|------|-----|----|--------|
| L N | USE CODE | CLS | LAND USE DESCRIPTION | CAP | R D | LOC ZONE | FRONT | DEPTH | TOT LND UTS | UNIT TYPE | D T | DPTH FACT | % COND | TOT ADJ | UNIT PRICE | ADJ UNIT PRICE | LAND VALUE | OTHER ADJUSTMENTS AND NOTES | YEAR | DENSITY | DECL | FRZ | YR | CONSRV |
| 1 | 000100 | C | RES | 100 | 0003 | R-2 | 0.00 | 0.00 | 55.00 | FF | | 1.00 | 1.00 | 1.00 | 5,000.00 | 5,000.00 | 275,000 | | | | | | | |