

BUILDING CHARACTERISTICS		
ELEMENT	CD	CONSTRUCTION
Exterior Wall	10	ABOVE AVG 100
Roof Structur	08	IRREGULAR 100
Roof Cover	03	COMP SHNGL 100
Interior Wall	05	DRYWALL 100
Interior Floor	14	CARPET 70
Interior Floor	15	HARDTILE 30
Air Condition	03	CENTRAL 100
Heating Type	04	AIR DUCTED 100
Bedrooms		3 100
Bathrooms		2 100
Frame	02	WOOD FRAME 100
Stories	1.	1. 100
Units		0 100
Occupancy	00	NONE 100

MARKET ADJUSTMENTS											
TYPE	MDL	EFF. AREA	TOT ADJ PTS	EFF. BASE RATE	REPL. COST NEW	AYB	EYB	ECON	FNCT	NORM	% COND
0500	11	2,628	137.6477	217.48	571,537	2004	2004	0	0	9.50	90.50

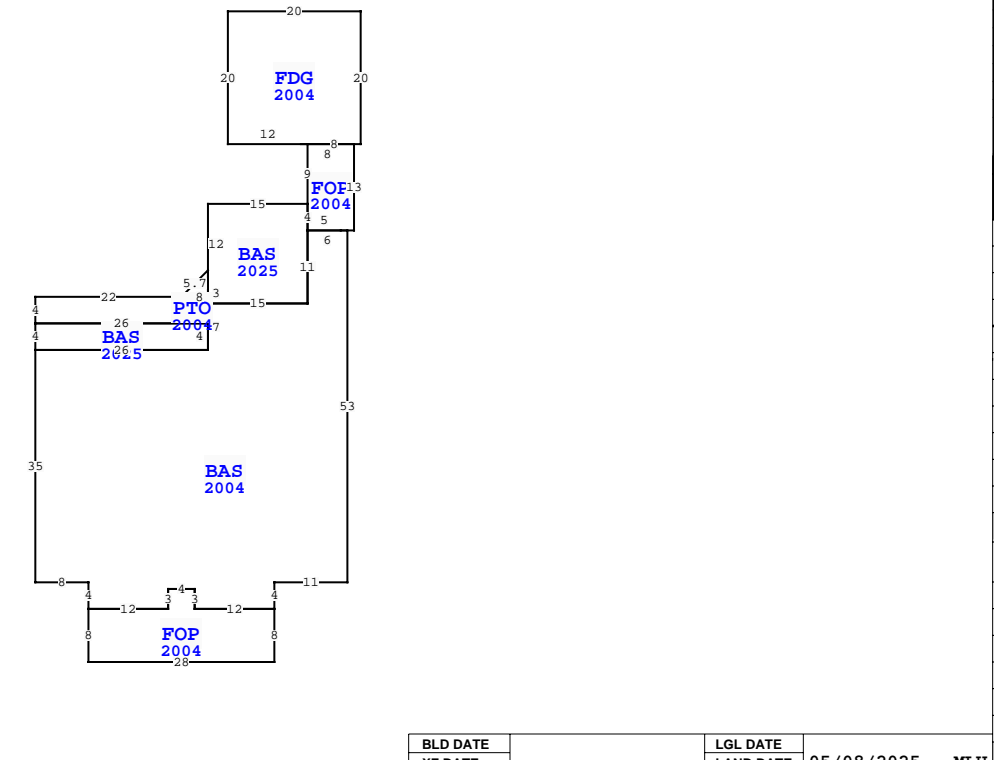

NASSAU COUNTY PROPERTY		PAGE 1 of 1	2
VALUATION SUMMARY			
VALUATION BY		STANDARD	
Tax Group: 2		Tax Dist:	
BUILDING MARKET VALUE		517,241	
TOTAL MARKET OB/XF VALUE		28,250	
TOTAL LAND VALUE - MARKET		300,000	
TOTAL MARKET VALUE		845,491	
SOH/AGL Deduction		89,866	
ASSESSED VALUE		755,625	
TOTAL EXEMPTION VALUE		HX HB 50,722	
BASE TAXABLE VALUE		704,903	
TOTAL JUST VALUE		845,491	
NCON VALUE		0	
INCOME VALUE			
PREVIOUS YEAR MKT VALUE		734,329	

Quality	03	Quality Level 03
DOR CODE	0100	SINGLE FAMILY
MAP NUM		MKT AREA 01
NEIGHBORHOOD/LOC	1031.00	
AREA TYPE	TOTAL GROSS AREA	PCT OF BASE
BAS	1,958	100
BAS	104	100
BAS	225	100
FDG	400	60
FOP	80	30
FOP	236	30
PTO	112	5
TOTALS	3,115	

PERMIT NUM	DESCRIPTION	AMT	ISSUED
2024-0177	ENCLOSE PORCH	48,000	04/24/2024
2023-0168	FG POOL 248SF	50,000	04/19/2023
20034292	NEW CONSTR	200,000	12/10/2003

SALES DATA						
OFF RECORD Number	DATE	TYPE INST	Q U	V I	RSN CD	SALE PRICE
2564/0283	5/18/2022	WD	Q	I	01	705,000

GRANTOR: SELLERS JOHN MARCUS &  
GRANTEE: CONNOLLY JOHN & ANN  
2549/1733 3/24/2022 FJ U I 11 0  
GRANTOR: SELLERS SARALYN L EST  
GRANTEE: SELLER JOHN MARCUS

EXTRA FEATURES											
L N	OB/XF CODE	DESCRIPTION	BLD CAP	L	W	UNITS	UT	Adj R	ADJ UNIT PRICE	ORIG COND	YEAR ON
1	0500	FP-PRE FAB	0	100	0	1.00	UT	3,500.00	3,500.00	100	2004
2	0819	CONC 12"	0	100	4	32.00	SF	9.50	9.50	100	2004
3	0810	CONCRETE A	0	100	10	80.00	SF	6.50	6.50	100	2004
4	0810	CONCRETE A	0	100	0	765.00	SF	6.50	6.50	100	2004
5	0470	VNYL GATE	0	100	0	1.00	UT	300.00	300.00	100	2004
6	0471	VINYL FNC	0	100	0	68.00	LF	32.00	32.00	100	2004
7	0469	VF LATTIC	0	100	0	13.00	SF	5.50	5.50	100	2004
8	0866	POOL FIBER	0	100	0	248.00	SF	72.00	72.00	100	2024
9	0855	CONC PAVER	0	100	0	152.00	SF	10.00	10.00	100	2024

TOTAL OB/XF												28,250			
L N	USE CODE	CLS	LAND USE DESCRIPTION	CAP	R D	LOC ZONE	FRONT	DEPTH	TOT LND UTS	UNIT TYPE	D T				
1	000100	C	RES	100		R-2	0.00	0.00	60.00	FF	1.00				

BUILDING NOTES											
BUILDING DIMENSIONS											
BAS=[YR=2004;ORIG=-49,53] S35 E8 S4 E12 N3 E4 S3 E12 N4 E11 N53 W6 S11 W15 S7 W26 \$											
FDG=[YR=2004;ORIG=0,2] W20 S20 E12 E8 N20 \$											
FOP=[YR=2004;ORIG=-8,22] S9 S4 DOR5 UOR2 N13 W8 \$											
PTO=[YR=2004;ORIG=-41,92] S8 E28 N8 W12 N3 W4 S3 W12 \$											
BAS=[YR=2004;ORIG=-23,41] D4L4 W22 S4 E26 N8 \$											
BAS=[YR=2025;ORIG=-49,49] S4 E26 N4 W26 \$											
BAS=[YR=2025;ORIG=-23,31] S12 S3 E15 N11 N4 W15 \$											

LAND DESCRIPTION												TOTAL OB/XF				28,250			
L N	USE CODE	CLS	LAND USE DESCRIPTION	CAP	R D	LOC ZONE	FRONT	DEPTH	TOT LND UTS	UNIT TYPE	D T								
1	000100	C	RES	100		R-2	0.00	0.00	60.00	FF	1.00								