

LOT 128
IN OR 1969/1793
ISLE DE MAI AT AMELIA #2

OBERHOLTZER LEMI C & DAVID M
2842 FERDINAND CT
FERNANDINA BEACH, FL 32034

2025

00-00-31-087I-0128-0000

BUILDING CHARACTERISTICS		CONSTRUCTION	
ELEMENT	CD		
Exterior Wall	16	WD FR STUC	100
Roof Structur	08	IRREGULAR	100
Roof Cover	03	COMP SHNGL	100
Interior Wall	05	DRYWALL	100
Interior Floo	11	CLAY TILE	70
Interior Floo	14	CARPET	30
Air Condition	03	CENTRAL	100
Heating Type	04	AIR DUCTED	100
Bedrooms		4	100
Bathrooms		3	100
Frame	02	WOOD FRAME	100
Stories	1.5	1.5	100
Units		0	100
Occupancy	00	NONE	100
Quality	03	Quality Level 03	
DOR CODE	0100	SINGLE FAMILY	
MAP NUM		MKT AREA	01
NEIGHBORHOOD/LOC	1079.00		
AREA TYPE	TOTAL GROSS AREA	PCT OF BASE	YEAR
BAS	2,439	100	2014
FGR	491	55	2014
FOP	94	30	2014
FSP	292	40	2014
FST	15	55	2014
FUS	360	100	2014
USP	250	30	2020
TOTALS	3,941		

MARKET ADJUSTMENTS											
TYPE	MDL	EFF. AREA	TOT ADJ PTS	EFF. BASE RATE	REPL. COST NEW	AYB	EYB	ECON	FNCT	NORM	% COND
1	SFR	CUST	- 100%	- 2015							
					Heated Area: 2799						
						HX Base Yr 2015					

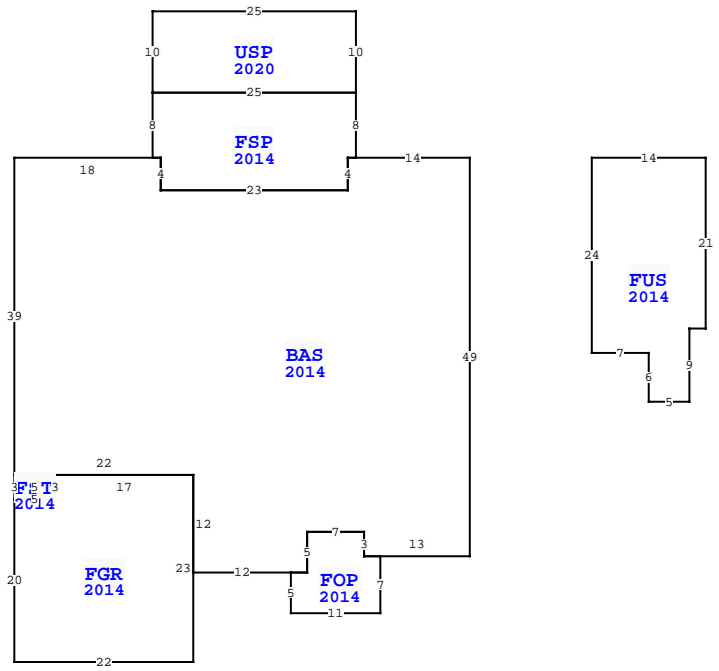

NASSAU COUNTY PROPERTY		PAGE 1 of 1	2
VALUATION SUMMARY			
VALUATION BY			STANDARD
Tax Group: 2	Tax Dist:		
BUILDING MARKET VALUE			596,487
TOTAL MARKET OB/XF VALUE			7,868
TOTAL LAND VALUE - MARKET			150,000
TOTAL MARKET VALUE			754,355
SOH/AGL Deduction			344,140
ASSESSED VALUE			410,215
TOTAL EXEMPTION VALUE	HX HB	50,722	
BASE TAXABLE VALUE			359,493
TOTAL JUST VALUE			754,355
NCON VALUE			0
INCOME VALUE			
PREVIOUS YEAR MKT VALUE			727,158

PERMIT NUM	DESCRIPTION	AMT	ISSUED
20200101	12X28 SCRNR	0	03/02/2020
20132527	NEW CONSTR	0	11/01/2013
20132051	NEW CONSTR	270,320	08/30/2013

SALES DATA						
OFF RECORD Number	DATE	TYPE INST	Q / U	V / I	RSN CD	SALE PRICE
1969/1793	2/17/2015	WD	U	I	11	100
GRANTOR: SEDA CONSTRUCTION COM						
GRANTEE: OBERHOLTZER LEMI C						
1955/0026	12/19/2014	WD	Q	I	01	359,900
GRANTOR: SEDA CONSTRUCTION COM						
GRANTEE: OBERHOLTZER LEMI C						

EXTRA FEATURES																
L N	OB/XF CODE	DESCRIPTION	BLD CAP	L	W	UNITS	UT	Adj R	ADJ UNIT PRICE	ORIG COND	YEAR ON	YEAR ACTUAL	Q	% COND	OB/XF MKT VALUE	NOTES
1	0855	CONC PAVER	0	100	0	0			528.00	100	2014	2014	3	94	3,474	
2	0855	CONC PAVER	0	100	0	0			110.00	100	2014	2014	3	94	1,034	
3	0500	FP-PRE FAB	0	100	0	0			1.00	100	2014	2014	3	96	3,360	

BLD DATE				LGL DATE			
XF DATE	INC DATE	LAND DATE	AG DATE				
		03/13/2024		MLU			

BUILDING NOTES	
BUILDING DIMENSIONS BAS=[YR=2014] W14 FSP=[YR=2014] N8USP=[YR=2020] N10 W25 S10 E25 \$ W25 S8 E1 S4 E23 N4 E1\$ W1 S4 W23 N4 W18 S39 FST=[YR=2014] S3 FGR=[YR=2014] S20E22 N23 W17 S3 W5\$ E5 N3 W5\$ E22 S12 E12 FOP=[YR=2014] S5 E11 N7 W2 N3 W7 S5 W2\$ E2 N5 E7 S3 E13 N49\$ PTR=E15 FUS=[YR=2014] E14 S21 W2 S9 W5 N6 W7 N24\$ W15\$.	

LAND DESCRIPTION		TOTAL OB/XF																						
L N	USE CODE	CLS	LAND USE DESCRIPTION	CAP	R D	LOC ZONE	FRONT	DEPTH	TOT LND UTS	UNIT TYPE	D T	DPH FACT	% COND	TOT ADJ	UNIT PRICE	ADJ UNIT PRICE	LAND VALUE	OTHER ADJUSTMENTS AND NOTES	YEAR	DENSITY	DECL	FRZ	YR	CONSRV
1	000100	C	RES	100	0003	R-1	0.00	0.00	1.00	LT		1.00	1.00	1.00	150,000.00	150,000.00	150,000							