

LOT 39 &  
 LOT 40 (EX S-1)  
 IN OR 1921/147

FAHEY JOANINA & PHILIP F  
 85736 AVANT RD  
 YULEE, FL 32097

2024

43-2N-27-4640-0039-0000

BUILDING CHARACTERISTICS	
ELEMENT	CD CONSTRUCTION
Exterior Wall	12 CEDAR 100
Roof Structur	08 IRREGULAR 100
Roof Cover	03 COMP SHNGL 100
Interior Wall	05 DRYWALL 100
Interior Floor	15 HARDTILE 90
Interior Floor	14 CARPET 10
Air Condition	03 CENTRAL 100
Heating Type	04 AIR DUCTED 100
Bedrooms	2 100
Bathrooms	4 100
Frame	02 WOOD FRAME 100
Stories	1.5 100
Units	0 100
Occupancy	00 NONE 100

MARKET ADJUSTMENTS														
TYPE	MDL	EFF. AREA	TOT ADJ PTS	EFF. BASE RATE	REPL. COST NEW	AYB	EYB	ECON	FNCT	NORM	% COND			
0900	01	4,850	113.5071	141.88	688,118	1991	1996	0	0	0	13.50	86.50		
1 SNGL FAM - 0% - 0 Heated Area: 3486 HX Base Yr														

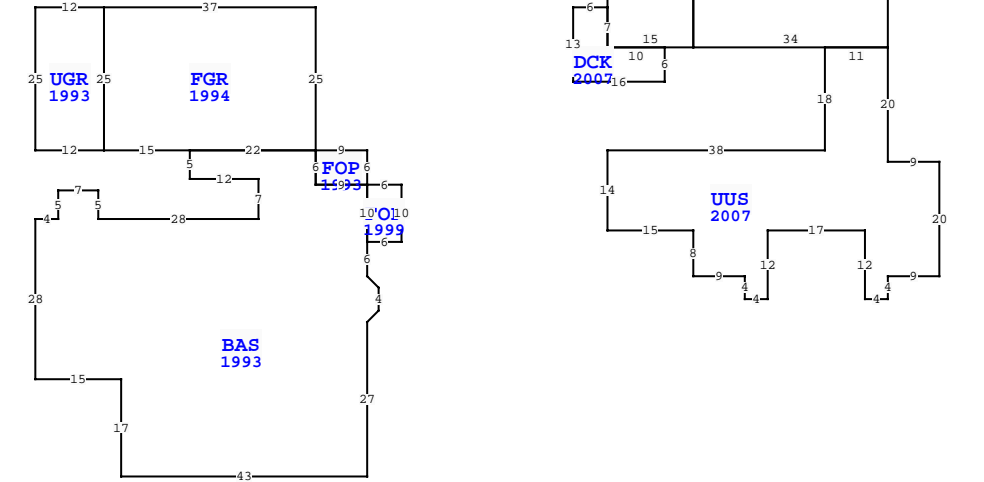

Quality	04 Quality Level 04			
DOR CODE	0100 SINGLE FAMILY			
MAP NUM	MKT AREA 04			
NEIGHBORHOOD/LOC	4082.00			
AREA TYPE	TOTAL GROSS AREA	PCT OF BASE	TOT ADJ AREA	SUBAREA MARKET VALUE
BAL	375	15	56	6,872
BAS	2,636	100	2,636	323,507
DCK	138	10	14	1,718
FGR	925	55	509	62,468
FOP	54	30	16	1,964
FOP	60	30	18	2,209
FUS	850	100	850	104,317
UGR	300	45	135	16,568
UUS	1,232	50	616	75,599
TOTALS	6,570		4,850	595,222

EXTRA FEATURES	
L N	OB/XF CODE

85736 AVANT RD, YULEE	BLD DATE	LGL DATE	04/29/2024	MLU
	XF DATE	LAND DATE		
	INC DATE	AG DATE		

L N	OB/XF CODE	DESCRIPTION	BLD	CAP	L	W	UNITS	UT	Adj R	ADJ UNIT PRICE	ORIG COND	YEAR ON	YEAR ACTUAL	Q	% COND	OB/XF MKT VALUE	NOTES
1	0812	CONCRETE C	0	0	0	0	2,188.00	SF	4.00	4.00	100	1991	1991	3	62	5,426	
2	0921	CWALL-CC P	0	0	0	0	100.00	LF	660.00	660.00	100	1980	1980	3	32.5	21,450	
3	1076	TRELLIS A	0	0	21	10	210.00	SF	7.50	7.50	100	1995	1995	3	20	315	
4	0322	BOAT LFT L	0	0	0	0	1.00	UT	1,500.00	1,500.00	100	1996	1996	3	20	300	
5	0311	WD GANG WY	0	0	0	0	15.00	SF	45.00	45.00	100	1996	1996	3	20	135	
6	0303	FLT DOCK W	0	0	12	13	156.00	SF	26.00	26.00	100	1996	1996	3	24	973	
7	0910	SCRN RM L	0	0	0	0	1,587.00	SF	15.00	15.00	100	2004	2004	3	22	5,237	
8	0855	CONC PAVR	0	0	0	0	1,194.00	SF	10.00	10.00	100	2004	2004	3	84	10,030	
9	0861	POOL GUNIT	0	0	30	13	390.00	SF	85.00	85.00	100	2004	2004	3	36	11,934	
10	0871	POOL HTR R	0	0	0	0	1.00	UT	2,000.00	2,000.00	100	2004	2004	3	22	440	

LAND DESCRIPTION		TOTAL OB/XF													
		56,240													

L N	USE CODE	CLS	LAND USE DESCRIPTION	CAP	R D	LOC ZONE	FRONT	DEPTH	TOT LND UTS	UNIT TYPE	D T	DPH FACT	% COND	TOT ADJ	UNIT PRICE	ADJ UNIT PRICE	LAND VALUE	OTHER ADJUSTMENTS AND NOTES	YEAR	DENSITY	DECL	FRZ	YR	CONSRV
1	000130	C	SFR WATER	0		RSF-1	100.00	185.00	100.00	FF		1.00	1.00	1.00	3,000.00	3,000.00	300,000							
2	000130	C	SFR WATER	0		RSF-1	10.00	192.00	10.00	FF		1.00	1.00	1.00	3,000.00	3,000.00	30,000							

NASSAU COUNTY PROPERTY		PAGE 1 of 2	
VALUATION SUMMARY			
VALUATION BY	Tax Group: 4	Tax Dist:	STANDARD
BUILDING MARKET VALUE			595,222
TOTAL MARKET OB/XF VALUE			68,814
TOTAL LAND VALUE - MARKET			330,000
TOTAL MARKET VALUE			994,036
SOH/AGL Deduction			177,574
ASSESSED VALUE			816,462
TOTAL EXEMPTION VALUE			0
BASE TAXABLE VALUE			816,462
TOTAL JUST VALUE			994,036
NCON VALUE			0
INCOME VALUE			
PREVIOUS YEAR MKT VALUE			916,517

PERMIT NUM	DESCRIPTION	AMT	ISSUED
B0311933	ADDITION	12,000	11/01/2003
B0311851	NEW CONSTR	34,922	10/01/2003
6936	NEW CONSTR	89,082	01/14/1991

SALES DATA						
OFF RECORD Number	DATE	TYPE INST	Q U	V I	RSN CD	SALE PRICE
1921/0147	5/28/2014	SW	U	I	12	380,000
GRANTOR: FANNIE MAE						
GRANTEE: FAHEY JOANINA & PHI						
1852/1670	3/26/2013	WD	U	I	12	100
GRANTOR: WILLIAMS KATHERINE L						
GRANTEE: FEDERAL NATIONAL MO						

BUILDING NOTES	

BUILDING DIMENSIONS	
FGR=[YR=1994] W37 UGR=[YR=1993] W12 S25 E12 N25\$ S25 E15	
BAS=[YR=1993] S5 E12 S7 W28 N5 W7 S5 W4 S28 E15 S17 E43 N27	
R2 U2 N4 U2 L2 N6 FOP=[YR=1999] E6 N10 W6 S10\$ N10	
POP=[YR=1993] N6 W9 S6 E9\$ W9 N6 W22 \$ E22 N25\$ PTR=E45	
DCK=[YR=2007] E6 BAL=[YR=2007] N18 E15 FUS=[YR=1993] E34 S25	
UUS=[YR=2007] S20 E9 S20 W9 S4 W4 N12 W17 S12 W4 N4 W9 N8 W15	
N14 E38 N18 E11\$ W34 N25\$ S25 W15 N7\$ S7 E10 S6 W16 N13\$ W45 \$.	

