

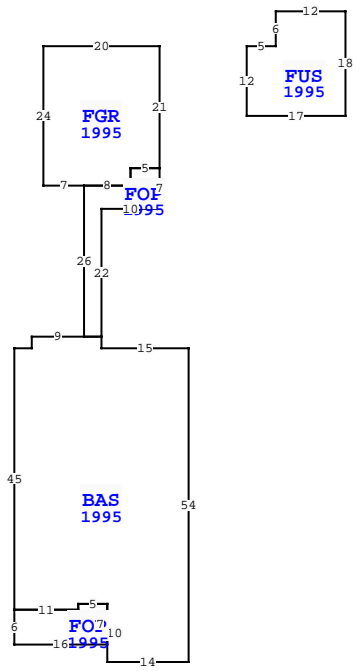

BUILDING CHARACTERISTICS		CONSTRUCTION	
ELEMENT	CD		
Exterior Wall	31	HARDIE BRD	100
Roof Structur	08	IRREGULAR	100
Roof Cover	03	COMP SHNGL	100
Interior Wall	05	DRYWALL	100
Interior Floo	11	CLAY TILE	80
Interior Floo	14	CARPET	20
Air Condition	03	CENTRAL	100
Heating Type	04	AIR DUCTED	100
Bedrooms		3	100
Bathrooms		2.5	100
Frame	02	WOOD FRAME	100
Stories	2.	2.	100
Units		0	100
Occupancy	00	NONE	100
Quality	04	Quality Level	04
DOR CODE	0100	SINGLE FAMILY	
MAP NUM		MKT AREA	04
NEIGHBORHOOD/LOC	4015.0100		
AREA TYPE	TOTAL GROSS AREA	PCT OF BASE	TOT ADJ AREA
BAS	1,495	100	1,495
FGR	465	55	256
FOP	101	30	30
FOP	133	30	40
FUS	276	100	276
TOTALS	2,470		2,097
			216,406

MARKET ADJUSTMENTS											
TYPE	MDL	EFF. AREA	TOT ADJ PTS	EFF. BASE RATE	REPL. COST NEW	AYB	EYB	ECON	FNCT	NORM	% COND
1	TOWNHOUSE	- 100%	- 2016		250,906	1995	1995	0	0	13.75	86.25
Heated Area: 1771 HX Base Yr 2016											



NASSAU COUNTY PROPERTY		PAGE 1 of 1	7
VALUATION SUMMARY			
VALUATION BY			STANDARD
Tax Group: 7	Tax Dist:		
BUILDING MARKET VALUE			216,406
TOTAL MARKET OB/XF VALUE			5,949
TOTAL LAND VALUE - MARKET			100,000
TOTAL MARKET VALUE			322,355
SOH/AGL Deduction			168,811
ASSESSED VALUE			153,544
TOTAL EXEMPTION VALUE	HX HB	50,000	
BASE TAXABLE VALUE			103,544
TOTAL JUST VALUE			322,355
NCON VALUE			0
INCOME VALUE			
PREVIOUS YEAR MKT VALUE			298,404

PERMIT NUM	DESCRIPTION	AMT	ISSUED

SALES DATA						
OFF RECORD Number	DATE	TYPE INST	Q / U	V / I	RSN CD	SALE PRICE
2006/1665	9/30/2015	WD	Q	I	02	200,000
GRANTOR: WILDES GWEN A						
GRANTEE: MCGRATH EILEEN						
0723/1021	2/07/1995	WD	Q	I		117,900
GRANTOR: TREVETT HOMES INC						
GRANTEE: WILDES GWEN A						

EXTRA FEATURES		91030 TEAL CT, FERNANDINA BEACH														
L N	OB/XF CODE	DESCRIPTION	BLD CAP	L	W	UNITS	UT	Adj R	ADJ UNIT PRICE	ORIG COND	YEAR ON	YEAR ACTUAL	Q	% COND	OB/XF MKT VALUE	NOTES
1	0500	FP-PRE FAB	0	100	0	1.00	UT	3,500.00	3,500.00	100	1995	1995	3	77	2,695	
2	0811	CONCRETE B	0	100	0	894.00	SF	5.20	5.20	100	1995	1995	3	70	3,254	

LAND DESCRIPTION		TOTAL OB/XF 5,949																						
L N	USE CODE	CLS	LAND USE DESCRIPTION	CAP	R D	LOC ZONE	FRONT	DEPTH	TOT LND UTS	UNIT TYPE	D T	DPH FACT	% COND	TOT ADJ	UNIT PRICE	ADJ UNIT PRICE	LAND VALUE	OTHER ADJUSTMENTS AND NOTES	YEAR	DENSITY	DECL	FRZ	YR	CONSRV
1	000100	C	SFR	100		PUD	0.00	0.00	1.00	LT		1.00	1.00	1.00	100,000.00	100,000.00	100,000							