

BUILDING CHARACTERISTICS		CONSTRUCTION	
ELEMENT	CD		
Exterior Wall	20	FACE BRICK	100
Roof Structur	03	GABLE/HIP	100
Roof Cover	03	COMP SHNGL	100
Interior Wall	05	DRYWALL	100
Interior Floo	14	CARPET	60
Interior Floo	13	LVT/LAMNT	40
Air Condition	03	CENTRAL	100
Heating Type	04	AIR DUCTED	100
Bedrooms		3	100
Bathrooms		2	100
Frame	02	WOOD FRAME	100
Stories	1.	1. 100	
Units		0	100
Occupancy	00	NONE	100
Quality	03	Quality Level	03
DOR CODE	0100	SINGLE FAMILY	
MAP NUM		MKT AREA	08
NEIGHBORHOOD/LOC	8124.00		
AREA TYPE	TOTAL GROSS AREA	PCT OF BASE	TOT ADJ AREA
BAS	2,127	100	2,127
FGR	588	55	323
FOP	60	30	18
FOP	64	30	19
PTO	810	5	40
PTO	187	5	9
TOTALS	3,836		2,536
			315,755

MARKET ADJUSTMENTS											
TYPE	MDL	EFF. AREA	TOT ADJ PTS	EFF. BASE RATE	REPL. COST NEW	AYB	EYB	ECON	FNCT	NORM	% COND
0900	01	2,536	103.4880	129.36	328,057	2018	2018	0	0	0	3.75
1 SNGL FAM - 100% - 2019 Heated Area: 2127 HX Base Yr 2019											

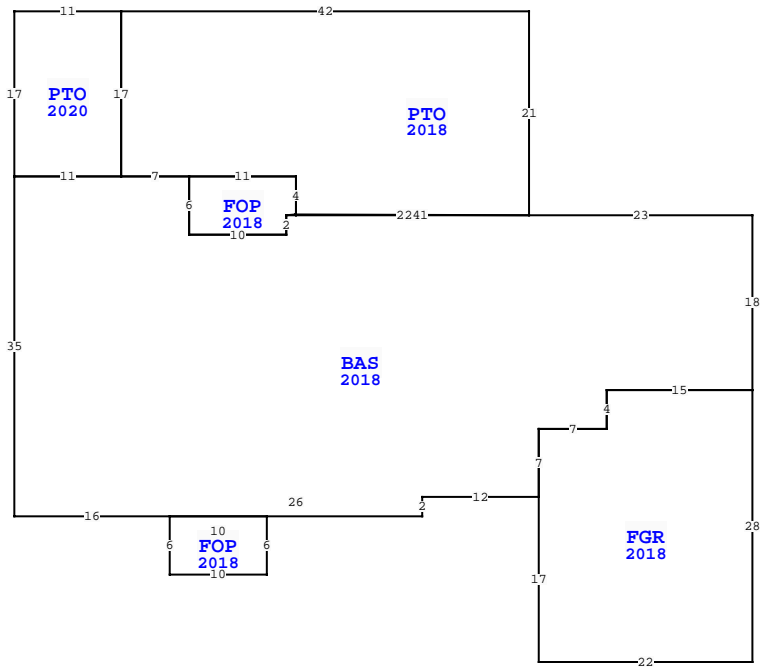

NASSAU COUNTY PROPERTY			
VALUATION SUMMARY			PAGE 1 of 2
VALUATION BY		STANDARD	
Tax Group: 6		Tax Dist:	
BUILDING MARKET VALUE		332,304	
TOTAL MARKET OB/XF VALUE		16,138	
TOTAL LAND VALUE - MARKET		60,000	
TOTAL MARKET VALUE		408,442	
SOH/AGL Deduction		122,083	
ASSESSED VALUE		286,359	
TOTAL EXEMPTION VALUE		HX HB 50,000	
BASE TAXABLE VALUE		236,359	
TOTAL JUST VALUE		408,442	
NCON VALUE		16,549	
INCOME VALUE			
PREVIOUS YEAR MKT VALUE		376,192	

PERMIT NUM	DESCRIPTION	AMT	ISSUED
20007340	GARAGE	26,565	08/17/2020
18011799	CO ISSUED	0	11/30/2018
18005134	NEW CONSTR	270,212	07/01/2018

SALES DATA						
OFF RECORD Number	DATE	TYPE INST	Q / U	V / I	RSN CD	SALE PRICE
2243/0790	12/11/2018	WD Q	Q	I	02	302,600
GRANTOR: KEN GREENE CONTRACTOR						
GRANTEE: ACEVEDO HELENA & ED						
2243/0785	12/11/2018	WD U	V	30		100
GRANTOR: KENNETH L GREENE CONT						
GRANTEE: KEN GREENE CONTRACT						

EXTRA FEATURES											
L N	OB/XF CODE	DESCRIPTION	BLD CAP	L	W	UNITS	UT	Adj R	ADJ UNIT PRICE	ORIG COND	YEAR ON
1	0812	CONCRETE C	0	100	0	2,073.00	SF	4.00	4.00	100	2018
2	0810	CONCRETE A	0	100	0	550.00	SF	6.50	6.50	100	2020
3	0810	CONCRETE A	0	100	0	708.00	SF	6.50	6.50	100	2020

TOTAL OB/XF											
L N	OB/XF CODE	DESCRIPTION	BLD CAP	L	W	UNITS	UT	Adj R	ADJ UNIT PRICE	ORIG COND	YEAR ON
52186 ALBANY PL, CALLAHAN											
BLD DATE											
XF DATE											
INC DATE											
LGL DATE											
LAND DATE											
AG DATE											
TOTAL OB/XF 16,138											

BUILDING NOTES											
BUILDING DIMENSIONS											

BAS=[YR=2018;ORIG=0,0] W23 U0.1L24.1 DO.1L0.11 S2 W10 N6 W7 W11 S35 E16 E26 N2 E12 N7 E7 N4 E15 N18 \$  
 PTO=[YR=2018;ORIG=-23,0] N21 W42 S17 E7 E11 S4 E24 \$  
 FGR=[YR=2018;ORIG=-22,29] S17 E22 N28 W15 S4 W7 S7 \$  
 PTO=[YR=2020;ORIG=-65,-21] W11 S17 E11 N17 \$  
 FOP=[YR=2018;ORIG=-58,-4] S6 E10 N2 E1 N4 W11 \$  
 FOP=[YR=2018;ORIG=-60,31] S6 E10 N6 W10 \$

LAND DESCRIPTION											
L N	USE CODE	CLS	LAND USE DESCRIPTION	CAP	R D	LOC ZONE	FRONT	DEPTH	TOT LND UTS	UNIT TYPE	D T
1	000100	C	SFR	100		OR	0.00	0.00	1.00	LT	1.00

LOT 51  
IN OR 2243/790  
GREENE TERRACE PBK 8/82

ACEVEDO HELENA & EDDIE  
52186 ALBANY PLACE  
CALLAHAN, FL 32011

2024

03-1N-25-0615-0051-0000

BUILDING CHARACTERISTICS				
ELEMENT	CD	CONSTRUCTION		
Exterior Wall	25	MOD METAL 100		
Roof Structur	10	STEEL FRME 100		
Roof Cover	12	MODULAR MT 100		
Interior Wall	07	NONE 100		
Interior Floor	03	CONC FINSH 100		
Air Condition	01	NONE 100		
Heating Type	01	NONE 100		
Bedrooms		0 100		
Bathrooms		0 100		
Frame	05	STEEL 100		
Quality 06 Quality Level 06				
DOR CODE 0100 SINGLE FAMILY				
MAP NUM		MKT AREA 08		
NEIGHBORHOOD/LOC 8124.00				
AREA TYPE	TOTAL GROSS AREA	PCT OF BASE	TOT ADJ AREA	SUBAREA MARKET VALUE
BAS	720	100	720	15,782
PTO	300	5	15	329
PTO	408	5	20	439
TOTALS	1,428		755	16,549

MARKET ADJUSTMENTS													
TYPE	MDL	EFF. AREA	TOT ADJ PTS	EFF. BASE RATE	REPL. COST NEW	AYB	EYB	ECON	FNCT	NORM	% COND		
2													
2 GARAGE RES - 100% - 2024 Heated Area: 720 HX Base Yr 2019													

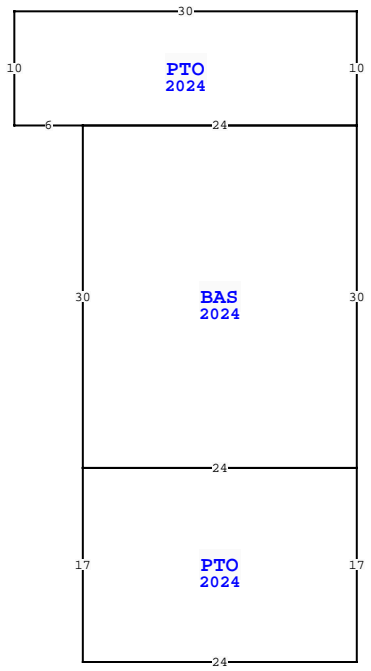

NASSAU COUNTY PROPERTY				PAGE 2 of 2	6	
VALUATION SUMMARY						
VALUATION BY		STANDARD				
Tax Group: 6		Tax Dist:				
BUILDING MARKET VALUE		332,304				
TOTAL MARKET OB/XF VALUE		16,138				
TOTAL LAND VALUE - MARKET		60,000				
TOTAL MARKET VALUE		408,442				
SOH/AGL Deduction		122,083				
ASSESSED VALUE		286,359				
TOTAL EXEMPTION VALUE		HX HB 50,000				
BASE TAXABLE VALUE		236,359				
TOTAL JUST VALUE		408,442				
NCON VALUE		16,549				
INCOME VALUE						
PREVIOUS YEAR MKT VALUE		376,192				
PERMIT NUM	DESCRIPTION	AMT	ISSUED			
SALES DATA						
OFF RECORD Number	DATE	TYPE INST	Q / U	V / I	RSN CD	SALE PRICE
2243/0790	12/11/2018	WD	Q	I	02	302,600
GRANTOR: KEN GREENE CONTRACTOR						
GRANTEE: ACEVEDO HELENA & ED						
2243/0785	12/11/2018	WD	U	V	30	100
GRANTOR: KENNETH L GREENE CONT						
GRANTEE: KEN GREENE CONTRACT						
BUILDING NOTES						
BUILDING DIMENSIONS						
BAS=[YR=2024;ORIG=50,10] E24 S30 W24 N30 \$						
PTO=[YR=2024;ORIG=50,40] E24 S17 W24 N17 \$						
PTO=[YR=2024;ORIG=74,10] W24 W6 N10 E30 S10 \$						

EXTRA FEATURES																
L N	OB/XF CODE	DESCRIPTION	BLD CAP	L	W	UNITS	UT	Adj R	ADJ UNIT PRICE	ORIG COND	YEAR ON	YEAR ACTUAL	Q	% COND	OB/XF MKT VALUE	NOTES
52186 ALBANY PL, CALLAHAN																
BLD DATE																
XF DATE																
INC DATE																
LGL DATE																
LAND DATE																
AG DATE																
TOTALS 0																

LAND DESCRIPTION																								
L N	USE CODE	CLS	LAND USE DESCRIPTION	CAP	R D	LOC ZONE	FRONT	DEPTH	TOT LND UTS	UNIT TYPE	D T	DPH FACT	% COND	TOT ADJ	UNIT PRICE	ADJ UNIT PRICE	LAND VALUE	OTHER ADJUSTMENTS AND NOTES	YEAR	DENSITY	DECL	FRZ	YR	CONSRV