

BUILDING CHARACTERISTICS		
ELEMENT	CD	CONSTRUCTION
Exterior Wall	17	CB STUCCO 100
Roof Structur	12	REINFO/CON 100
Roof Cover	02	ROLL COMP 100
Interior Wall	05	DRYWALL 100
Interior Floor	15	HARDTILE 100
Air Condition	03	CENTRAL 100
Heating Type	04	AIR DUCTED 100
Bedrooms		5 100
Bathrooms		8 100
Frame	03	MASONRY 100
Stories	3.	3. 100
Units		0 100

MARKET ADJUSTMENTS												
TYPE	MDL	EFF. AREA	TOT ADJ PTS	EFF. BASE RATE	REPL. COST NEW	AYB	EYB	ECON	FNCT	NORM	% COND	
2	DUPLX	- 0%	- 0									
Heated Area: 7438						HX Base Yr						

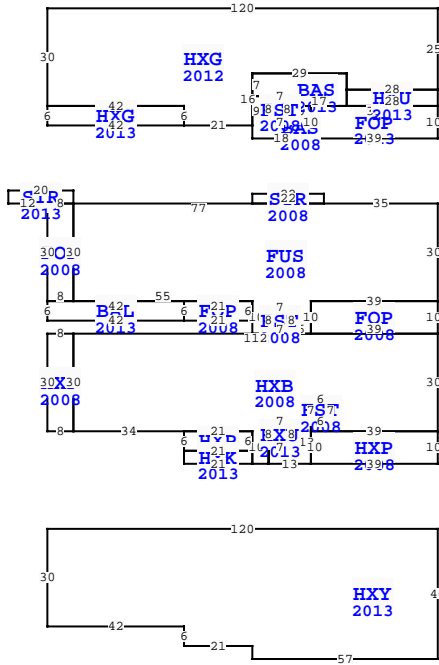

** This building has 23 Sub-Areas
3036 S FLETCHER AVE, FERNANDINA BEACH

BLD DATE	LGL DATE	05/07/2024	MLU
XF DATE	LAND DATE		
INC DATE	AG DATE		

NASSAU COUNTY PROPERTY			
VALUATION SUMMARY		PAGE 1 of 2	
VALUATION BY	Tax Group: 2	Tax Dist:	STANDARD
BUILDING MARKET VALUE	2,521,132		
TOTAL MARKET OB/XF VALUE	165,903		
TOTAL LAND VALUE - MARKET	825,000		
TOTAL MARKET VALUE	3,512,035		
SOH/AGL Deduction	0		
ASSESSED VALUE	3,512,035		
TOTAL EXEMPTION VALUE	0		
BASE TAXABLE VALUE	3,512,035		
TOTAL JUST VALUE	3,512,035		
NCON VALUE	0		
INCOME VALUE			
PREVIOUS YEAR MKT VALUE	3,338,874		

PERMIT NUM	DESCRIPTION	AMT	ISSUED
20152915	POOL	130,000	12/16/2015
20130652	SVC SEP	11,000	04/01/2013
20130471	H/AC	3,000	03/08/2013
20130481	DUNEWALK	25,000	03/08/2013
20130416	REMODEL	161,700	03/01/2013
20130093	DEMOLITION	6,000	01/14/2013

SALES DATA						
OFF RECORD Number	DATE	TYPE	Q	V	RSN	SALE PRICE
2418/0400	12/18/2020	WD	Q	I	01	3,050,000
GRANTOR: WARD DANIEL T LIVING						
GRANTEE: GREEN TURTLE INVEST						
1831/1753	12/21/2012	WD	Q	I	02	1,400,000
GRANTOR: HERITAGE BANK OF NORT						
GRANTEE: WARD DANIEL T TRUST						

BLD DATE		LGL DATE	
XF DATE	INC DATE	LAND DATE	AG DATE
		05/07/2024	MLU

EXTRA FEATURES		TOTAL OB/XF	
L N	OB/XF CODE	DESCRIPTION	VALUE
1	0861	POOL GUNIT	65,063
2	0855	CONC PAVER	25,920
3	0462	ST/AL FNC	1,426
4	1126	CB/STC 8"	4,147
5	0871	POOL HTR R	1,480
6	0476	VF 6 SBPL	995
7	0410	ELEVATOR	30,000
8	0855	CONC PAVER	744
9	0855	CONC PAVER	1,625
10	0855	CONC PAVER	895

LAND DESCRIPTION		TOTAL OB/XF	
L N	USE CODE	DESCRIPTION	VALUE
1	000120	C SFR OCN FT	825,000

