

BLOCK 5 LOT 1A  
IN OR 1492/960  
AMELIA PARK PHASE 1 UNIT 1

TOLG JOHN D & TOLG NIAMH ANNE  
1797 ARBOR DR  
FERNANDINA BEACH, FL 32034

**2024**

00-00-31-102P-0005-01A0

BUILDING CHARACTERISTICS		CONSTRUCTION	
ELEMENT	CD		
Exterior Wall	16	WD FR STUC	100
Roof Structur	03	GABLE/HIP	100
Roof Cover	03	COMP SHNGL	100
Interior Wall	05	DRYWALL	100
Interior Floor	14	CARPET	70
Interior Floor	11	CLAY TILE	30
Air Condition	03	CENTRAL	100
Heating Type	04	AIR DUCTED	100
Bedrooms		3	100
Bathrooms		2.5	100
Frame	02	WOOD FRAME	100
Stories	1.5	1.5	100
Units		0	100
Quality	06	Quality Level 06	
DOR CODE	0100	SINGLE FAMILY	
MAP NUM		MKT AREA	01
NEIGHBORHOOD/LOC	1031.00		
AREA TYPE	TOTAL GROSS AREA	PCT OF BASE	TOT ADJ AREA
BAS	1,237	100	1,237
FDG	420	60	252
FOP	80	30	24
FOP	132	30	40
FSP	45	40	18
FSP	180	40	72
FUS	717	100	717
TOTALS	2,811		2,360
			456,585

MARKET ADJUSTMENTS												
TYPE	MDL	EFF. AREA	TOT ADJ PTS	EFF. BASE RATE	REPL. COST NEW	AYB	EYB	ECON	FNCT	NORM	% COND	
1	TOWNHOUSE	- 0%	- 2024		513,017	2001	2001	0	0	0	11.00	89.00
Heated Area: 1954 HX Base Yr												

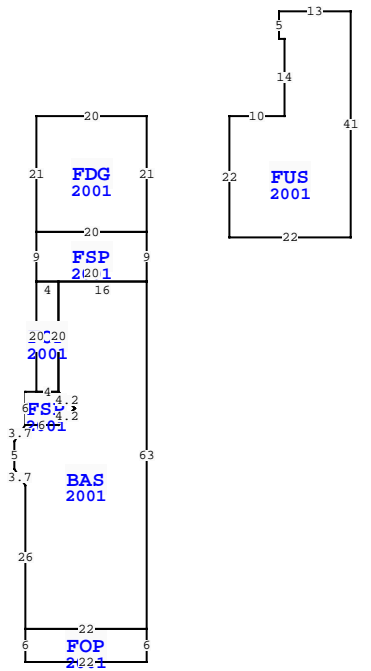

NASSAU COUNTY PROPERTY		PAGE 1 of 1	2
VALUATION SUMMARY			
VALUATION BY			STANDARD
Tax Group: 2	Tax Dist:		
BUILDING MARKET VALUE			456,585
TOTAL MARKET OB/XF VALUE			7,256
TOTAL LAND VALUE - MARKET			88,000
TOTAL MARKET VALUE			551,841
SOH/AGL Deduction			0
ASSESSED VALUE			551,841
TOTAL EXEMPTION VALUE			0
BASE TAXABLE VALUE			551,841
TOTAL JUST VALUE			551,841
NCON VALUE			0
INCOME VALUE			
PREVIOUS YEAR MKT VALUE			532,562

PERMIT NUM	DESCRIPTION	AMT	ISSUED
2003651	NEW CONSTR	121,000	08/08/2000

SALES DATA						
OFF RECORD Number	DATE	TYPE INST	Q / U	V / I	RSN CD	SALE PRICE
1492/0960	4/13/2007	WD	Q	I		395,000
GRANTOR: BRADDOCK JESSICA						
GRANTEE: TOLG JOHN D & NIAMH						
1360/1198	10/21/2005	WD	Q	I		385,000
GRANTOR: TUNANIDAS PETER & ELI						
GRANTEE: BRADDOCK JESSICA						

EXTRA FEATURES												
L N	OB/XF CODE	DESCRIPTION	BLD	CAP	L	W	UNITS	UT	Adj R	ADJ UNIT PRICE	ORIG COND	YEAR ON
1	0500	FP-PRE FAB	0	0	0	0	1.00	UT	3,500.00	3,500.00	100	2001
2	0877	JACUZZI	0	0	0	0	1.00	UT	1,000.00	1,000.00	100	2001
3	0962	SKYLIGHT	0	0	0	0	1.00	UT	250.00	250.00	100	2001
4	0819	CONC 12"	0	0	3	11	33.00	SF	9.50	9.50	100	2001
5	0819	CONC 12"	0	0	36	4	144.00	SF	9.50	9.50	100	2001
6	0810	CONCRETE A	0	0	3	11	33.00	SF	6.50	6.50	100	2001
7	0810	CONCRETE A	0	0	21	16	336.00	SF	6.50	6.50	100	2001
8	0470	VNYL GATE	0	0	0	0	1.00	UT	300.00	300.00	100	2001
9	0476	VF 6 SBPL	0	0	0	0	23.00	LF	16.00	16.00	100	2001
10	0476	VF 6 SBPL	0	0	0	0	30.00	LF	16.00	16.00	100	2000

TOTAL OB/XF												
7,256												
BLD DATE	XF DATE	INC DATE	LGL DATE	LAND DATE	AG DATE							
			03/21/2024			MLU						

BUILDING NOTES												

BUILDING DIMENSIONS												
FDG=[YR=2001] W20 S21 FSP=[YR=2001] S9 FOP=[YR=2001] S20 FSP=[YR=2001] W2 S6 BAS=[YR=2001] D3 L2 S5 R2 D3 S26 FOP=[YR=2001] S6 E22 N6 W22 \$ E22 N63 W16 S20 R3 D3 D3 L3 W6 \$ E6 U3 R3 U3 L3 W4\$ E4 N20 W4 \$ E20 N9 W20 \$ E20 N21 \$ PTR= E15 FUS=[YR=2001] E10 N14 W1 N5 E13 S41W22 N22 \$ W15 \$												

LAND DESCRIPTION													TOTAL OB/XF												
L N	USE CODE	CLS	LAND USE DESCRIPTION	CAP	R D	LOC ZONE	FRONT	DEPTH	TOT LND UTS	UNIT TYPE	D T	DPH FACT	% COND	TOT ADJ	UNIT PRICE	ADJ UNIT PRICE	LAND VALUE	OTHER ADJUSTMENTS AND NOTES	YEAR	DENSITY	DECL	FRZ	YR	CONSRV	
1	000100	C	SFR	0		R-2	0.00	0.00	22.00	FF		1.00	1.00	1.00	4,000.00	4,000.00	88,000								