

LOT 1
IN OR 1927/1692
BAYVIEW ESTATES PB 5/364

MORRISON THOMAS E JR & LISA MARIE
1417 SADLER RD #376
FERNANDINA BEACH, FL 32034

2023

46-3N-28-5060-0001-0000

BUILDING CHARACTERISTICS		CONSTRUCTION	
ELEMENT	CD		
Exterior Wall	10	ABOVE AVG	60
Exterior Wall	16	WD FR STUC	40
Roof Structure	08	IRREGULAR	100
Roof Cover	12	MODULAR MT	100
Interior Wall	05	DRYWALL	100
Interior Floor	12	HARDWOOD	50
Interior Floor	14	CARPET	50
Air Condition	03	CENTRAL	100
Heating Type	04	AIR DUCTED	100
Bedrooms		3	100
Bathrooms		2	100
Frame	02	WOOD FRAME	100
Stories	2.	2.100	
Units		0	100
Occupancy	00	NONE	100

MARKET ADJUSTMENTS														
TYPE	MDL	EFF. AREA	TOT ADJ PTS	EFF. BASE RATE	REPL. COST NEW	AYB	EYB	ECON	FNCT	NORM	% COND			
0900	01	2,450	106.5995	126.59	310,146	1994	2000	0	0	0	10.70	89.30		

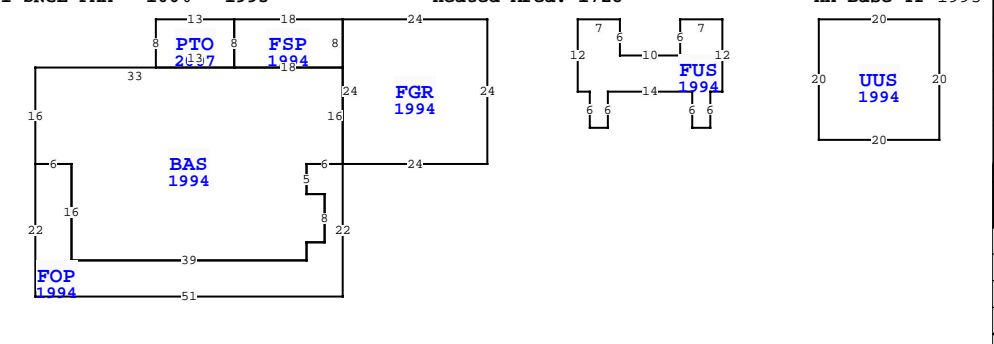

NASSAU COUNTY PROPERTY			
VALUATION SUMMARY			PAGE 1 of 1
VALUATION BY		STANDARD	
Tax Group: 4	Tax Dist:		
BUILDING MARKET VALUE			276,960
TOTAL MARKET OB/XF VALUE			3,371
TOTAL LAND VALUE - MARKET			358,720
TOTAL MARKET VALUE			639,051
SOH/AGL Deduction			434,232
ASSESSED VALUE			204,819
TOTAL EXEMPTION VALUE	HX HB	50,000	
BASE TAXABLE VALUE			154,819
TOTAL JUST VALUE			639,051
NCON VALUE			0
INCOME VALUE			
PREVIOUS YEAR MKT VALUE			605,334

Quality	02	Quality Level 02		
DOR CODE	0100	SINGLE FAMILY		
MAP NUM		MKT AREA 04		
NEIGHBORHOOD/LOC	4020.00			
AREA TYPE	TOTAL GROSS AREA	PCT OF BASE	TOT ADJ AREA	SUBAREA MARKET VALUE
BAS	1,464	100	1,464	165,498
FGR	576	55	317	35,835
FOP	474	30	142	16,053
FSP	144	40	58	6,556
FUS	264	100	264	29,844
PTO	104	5	5	565
UUS	400	50	200	22,609
TOTALS	3,426		2,450	276,960

PERMIT NUM	DESCRIPTION	AMT	ISSUED
B2000733	(20) WINDOWS	65,000	01/01/2020
B23041	REPAIR/RRF	21,500	11/01/2009
94-0680	NEW CONSTR	94,275	12/01/1993

SALES DATA						
OFF RECORD Number	DATE	TYPE INST	Q / U	V / I	RSN CD	SALE PRICE
1927/1692	7/14/2014	QC	U	I	11	100

GRANTOR: MORRISON THOMAS EDWAR		GRANTEE: MORRISON THOMAS EDW	
0777/1049	11/21/1996	QC	U I 06
GRANTOR: MORRISON JENNY SAUNDE		GRANTEE: MORRISON THOMAS EDW	

BLD DATE	03/03/2023	NW	LGL DATE	06/05/2023	MLU
XF DATE		INC DATE			

EXTRA FEATURES																
L N	OB/XF CODE	DESCRIPTION	BLD CAP	L	W	UNITS	UT	Adj R	ADJ UNIT PRICE	ORIG COND	YEAR ON	YEAR ACTUAL	Q	% COND	OB/XF MKT VALUE	NOTES
1	0812	CONCRETE C	0	100	0	0			4.00	100	1994	1994	3	70	3,371	

LAND DESCRIPTION														TOTAL OB/XF										
L N	USE CODE	CLS	LAND USE DESCRIPTION	CAP	R D	LOC ZONE	FRONT	DEPTH	TOT LND UTS	UNIT TYPE	D	DPH FACT	% COND	TOT ADJ	UNIT PRICE	ADJ UNIT PRICE	LAND VALUE	OTHER ADJUSTMENTS AND NOTES	YEAR	DENSITY	DECL	FRZ	YR	CONSRV
1	000130	C	SFR WATER	100	0006	RS-1	210.00	575.00	2.36	AC		1.00	1.00	0.95	160,000.00	152,000.00	358,720							

LAND DESCRIPTION														TOTAL OB/XF										
L N	USE CODE	CLS	LAND USE DESCRIPTION	CAP	R D	LOC ZONE	FRONT	DEPTH	TOT LND UTS	UNIT TYPE	D	DPH FACT	% COND	TOT ADJ	UNIT PRICE	ADJ UNIT PRICE	LAND VALUE	OTHER ADJUSTMENTS AND NOTES	YEAR	DENSITY	DECL	FRZ	YR	CONSRV
1	000130	C	SFR WATER	100	0006	RS-1	210.00	575.00	2.36	AC		1.00	1.00	0.95	160,000.00	152,000.00	358,720							