

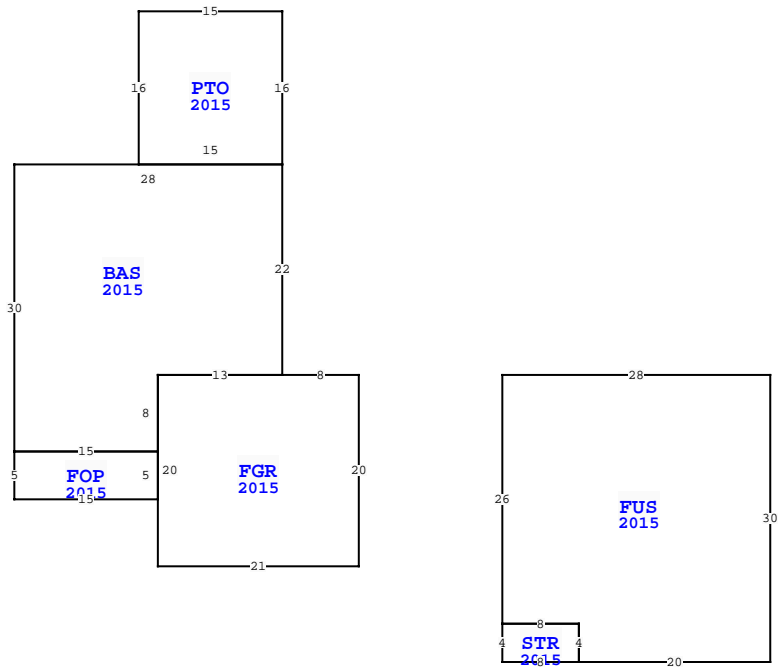

BUILDING CHARACTERISTICS		CONSTRUCTION	
ELEMENT	CD		
Exterior Wall	05	AVERAGE 70	
Exterior Wall	16	WD FR STUC 30	
Roof Structure	03	GABLE/HIP 100	
Roof Cover	03	COMP SHNGL 100	
Interior Wall	05	DRYWALL 100	
Interior Floor	14	CARPET 80	
Interior Floor	08	SHT VINYL 20	
Air Condition	03	CENTRAL 100	
Heating Type	04	AIR DUCTED 100	
Bedrooms		3 100	
Bathrooms		2.5 100	
Frame	02	WOOD FRAME 100	
Stories	2.	2. 100	
Units		0 100	
Occupancy	00	NONE 100	
Quality	06	Quality Level 06	
DOR CODE	0100	SINGLE FAMILY	
MAP NUM		MKT AREA	04
NEIGHBORHOOD/LOC	4107.00		
AREA TYPE	TOTAL GROSS AREA	PCT OF BASE	TOT ADJ AREA
BAS	736	100	736
FGR	420	55	231
FOP	75	30	22
FUS	808	100	808
PTO	240	5	12
STR	32	10	3
TOTALS	2,311		1,812

MARKET ADJUSTMENTS											
TYPE	MDL	EFF. AREA	TOT ADJ PTS	EFF. BASE RATE	REPL. COST NEW	AYB	EYB	ECON	FNCT	NORM	% COND
0100	01	1,812	125.2350	113.02	204,792	2015	2015	0	0	0	96.85
1 SINGLE FAM - 100% - 2016											
Heated Area: 1544											
HX Base Yr 2016											



NASSAU COUNTY PROPERTY		PAGE 1 of 1	4
VALUATION SUMMARY			
VALUATION BY			STANDARD
Tax Group: 4	Tax Dist:		
BUILDING MARKET VALUE			198,341
TOTAL MARKET OB/XF VALUE			3,883
TOTAL LAND VALUE - MARKET			75,000
TOTAL MARKET VALUE			277,224
SOH/AGL Deduction			109,359
ASSESSED VALUE			167,865
TOTAL EXEMPTION VALUE	HX HB	50,000	
BASE TAXABLE VALUE			117,865
TOTAL JUST VALUE			277,224
NCON VALUE			0
INCOME VALUE			
PREVIOUS YEAR MKT VALUE			227,641

PERMIT NUM	DESCRIPTION	AMT	ISSUED
B1530752	CO ISSUED	0	09/25/2015
B1530752	NEW CONSTR	198,783	07/01/2015

SALES DATA						
OFF RECORD Number	DATE	TYPE INST	Q / U	V / I	RSN CD	SALE PRICE
2005/1009	9/25/2015	SW	Q	I	01	192,600

GRANTOR: CYPRESS TRAILS LLC
GRANTEE: TAYLOR ROBERT ROGER

BUILDING NOTES	
BUILDING DIMENSIONS	
FGR=[YR=2015] W8 BAS=[YR=2015] N22 PTO=[YR=2015] N16 W15 S16 E15\$ W28 S30 FOP=[YR=2015] S5 E15 N5 W15\$ E15 N8 E13\$ W13 S20 E21 N20\$ PTR=E15 FUS=[YR=2015] E28 S30 W20 STR=[YR=2015] W8 N4 E8 S4\$ N4 W8 N26\$ W15\$.	

EXTRA FEATURES																	
L N	OB/XF CODE	DESCRIPTION	BLD CAP	L	W	UNITS	UT	Adj R	ADJ UNIT PRICE	ORIG COND	YEAR ON	YEAR ACTUAL	Q	% COND	OB/XF MKT VALUE	NOTES	
1	0811	CONCRETE B	0	100	0	0			708.00	SF	5.20	2015	2015	3	96	3,534	
2	0810	CONCRETE A	0	100	14	4			56.00	SF	6.50	2015	2015	3	96	349	

LAND DESCRIPTION															TOTAL OB/XF									
L N	USE CODE	CLS	LAND USE DESCRIPTION	CAP	R D	LOC ZONE	FRONT	DEPTH	TOT LND UTS	UNIT TYPE	D T	DPH FACT	% COND	TOT ADJ	UNIT PRICE	ADJ UNIT PRICE	LAND VALUE	OTHER ADJUSTMENTS AND NOTES	YEAR	DENSITY	DECL	FRZ	YR	CONSRV
1	000100	C	SFR			PUD	0.00	0.00	1.00	LT		1.00	1.00	1.00	75,000.00	75,000.00	75,000							