

BUILDING CHARACTERISTICS	
ELEMENT	CD CONSTRUCTION
Exterior Wall	16 WD FR STUC 70
Exterior Wall	17 CB STUCCO 30
Roof Structure	08 IRREGULAR 100
Roof Cover	07 CONC TILE 100
Interior Wall	05 DRYWALL 100
Interior Floor	11 CLAY TILE 50
Interior Floor	14 CARPET 50
Air Condition	03 CENTRAL 100
Heating Type	04 AIR DUCTED 100
Bedrooms	6 100
Bathrooms	4.5 100
Frame	02 WOOD FRAME 100
Stories	3. 3. 100
Units	0 100

MARKET ADJUSTMENTS											
TYPE	MDL	EFF. AREA	TOT ADJ PTS	EFF. BASE RATE	REPL. COST NEW	AYB	EYB	ECON	FNCT	NORM	% COND
1	SFR	CUST - 100%	- 2003		Heated Area: 4506					HX	Base Yr 2003

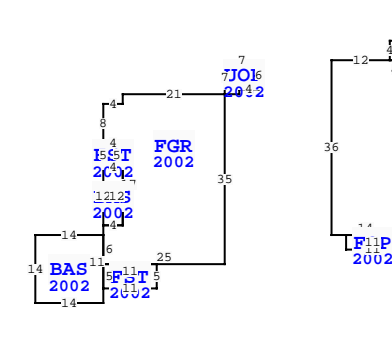
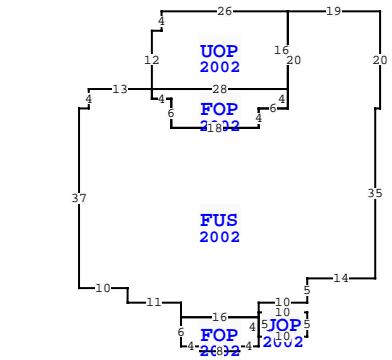

Quality	04 Quality Level 04			
DOR CODE	0100 SINGLE FAMILY			
MAP NUM	MKT AREA 10			
NEIGHBORHOOD/LOC	10014.00			
AREA TYPE	TOTAL GROSS AREA	PCT OF BASE	TOT ADJ AREA	SUBAREA MARKET VALUE
BAS	48	100	48	12,687
BAS	196	100	196	51,807
FGR	799	55	439	116,037
FOP	33	30	10	2,643
FOP	33	30	10	2,643
FOP	90	30	27	7,137
FOP	104	30	31	8,194
FOP	156	30	47	12,423
FOP	176	30	53	14,009
FST	20	55	11	2,908
TOTALS	6,507		5,271	1,393,236

** This building has 16 Sub-Areas
24 OCEAN CLUB DR, FERNANDINA BEACH

BLD DATE	LGL DATE
XF DATE	LAND DATE
INC DATE	AG DATE

NASSAU COUNTY PROPERTY		PAGE 1 of 1	5
VALUATION SUMMARY		STANDARD	
VALUATION BY	Tax Group: 5	Tax Dist:	
BUILDING MARKET VALUE			1,393,236
TOTAL MARKET OB/XF VALUE			21,623
TOTAL LAND VALUE - MARKET			900,000
TOTAL MARKET VALUE			2,314,859
SOH/AGL Deduction			1,259,395
ASSESSED VALUE			1,055,464
TOTAL EXEMPTION VALUE	HX HB		50,000
BASE TAXABLE VALUE			1,005,464
TOTAL JUST VALUE			2,314,859
NCON VALUE			0
INCOME VALUE			
PREVIOUS YEAR MKT VALUE			1,942,668

PERMIT NUM	DESCRIPTION	AMT	ISSUED
B0108374	NEW CONSTR	375,000	06/01/2001

SALES DATA						
OFF RECORD Number	DATE	TYPE INST	Q / U	V / I	RSN CD	SALE PRICE
1755/1360	7/29/2011	QC	U	I	11	100

GRANTOR: WILLIAMS JAMES E & NA
GRANTEE: WILLIAMS JAMES E &
0866/0072 2/05/1999 WD Q V 255,000
GRANTOR: AMELIA ISLAND COMPANY
GRANTEE: WILLIAMS JAMES & NA

BUILDING NOTES	
----------------	--

BUILDING DIMENSIONS	
UOP=[YR=2002]	W7 S7 FGR=[YR=2002] W21 S2 W4 S8
FST=[YR=2002]	S5 BAS=[YR=2002] S12 E4 N12 W4 \$ E4 N5 W4 \$
E4 S17 W4 S2 BAS=[YR=2002]	W14 S14 E14 N3 FST=[YR=2002] E11
N5 W11 S5 \$ N11 \$ S6 E25 N35 \$ E3 N1 E4 N6 \$ PTR= N15	
FOP=[YR=2002]	N2 UOP=[YR=2002] E10 N5 W10 FUS=[YR=2002] N2
E10 N5 E14 N35 E1 N20 W19 UOP=[YR=2002]	W26 S4 W2 S12
FOP=[YR=2002]	S2 E4 S6 E18 N4 E6 N4 W28 \$ E28 N16 \$ S20 W6
S4 W18 N6 W4 N2 W13 S4 W2 S37 E10 S3 E11 S3 E16 N1 \$S5\$ N4	
W16 S6 E4 S1 E8N1 E4 \$ S15 \$ PTR= E15 FUS=[YR=2002] E12	
FOP=[YR=2002]	N4 E21 S4 W2 S4 W18 N4 W1 \$ E1 S4 E18 N4 E12
S31 W3 S5 FOP=[YR=2002]	S3 W11 FOP=[YR=2002] S6 W15 N6
FOP=[YR=2002]	W11 N3 E11 S3 \$ E15 \$ N3 E11 \$ W11 S3 W15 N3

L N	OB/XF CODE	DESCRIPTION	BLD CAP	L	W	UNITS	UT	Adj R	ADJ UNIT PRICE	ORIG COND	YEAR ON	YEAR ACTUAL	Q	% COND	OB/XF MKT VALUE	NOTES
1	0504	FP-ELECTRI	0	100	0	0		1.00	UT 2,000.00	2,000.00	100	2002	2002	3	87	1,740
2	0812	CONCRETE C	0	100	0	0		1,524.00	SF 4.00	4.00	100	2002	2002	3	83	5,060
3	0858	SCULP CONC	0	100	0	0		532.00	SF 13.00	13.00	100	2002	2002	3	95	6,570
4	0858	SCULP CONC	0	100	0	0		137.00	SF 13.00	13.00	100	2002	2002	3	95	1,692
5	1126	CB/STC 8"	0	100	0	0		100.00	SF 8.00	8.00	100	2002	2002	3	83	664
6	0920	CWALL-WD/M	0	100	0	0		72.00	LF 390.00	390.00	100	2002	2002	3	21	5,897

LAND DESCRIPTION		TOTAL OB/XF														21,623								
L N	USE CODE	CLS	LAND USE DESCRIPTION	CAP	R D	LOC ZONE	FRONT	DEPTH	TOT LND UTS	UNIT TYPE	D T	DPTH FACT	% COND	TOT ADJ	UNIT PRICE	ADJ UNIT PRICE	LAND VALUE	OTHER ADJUSTMENTS AND NOTES	YEAR	DENSITY	DECL	FRZ	YR	CONSRV
1	000100	C	SFR				0.00	0.00	1.00	LT		1.00	1.00	0.90	1,000,000.00	900,000.00	900,000							