

LOT 16
IN OR 1815/1763
OCEAN CLUB DRIVE PB 6/107-110

AMOS BRENDA R
38 OCEAN CLUB DR
FERNANDINA BEACH, FL 32034

2023

01-6N-29-150C-0016-0000

ELEMENT	CD	CONSTRUCTION
Exterior Wall	14	WD SHINGLE 70
Exterior Wall	17	CB STUCCO 30
Roof Structure	08	IRREGULAR 100
Roof Cover	07	CONC TILE 100
Interior Wall	05	DRYWALL 100
Interior Floor	14	CARPET 60
Interior Floor	11	CLAY TILE 40
Air Condition	03	CENTRAL 100
Heating Type	04	AIR DUCTED 100
Bedrooms		4 100
Bathrooms		5 100
Frame	02	WOOD FRAME 100
Stories	3.	3. 100
Units		0 100

MARKET ADJUSTMENTS												
TYPE	MDL	EFF. AREA	TOT ADJ PTS	EFF. BASE RATE	REPL. COST NEW	AYB	EYB	ECON	FNCT	NORM	% COND	
1	SFR	CUST - 100%	- 2015									
				Heated Area:	3754				HX Base Yr	2015		

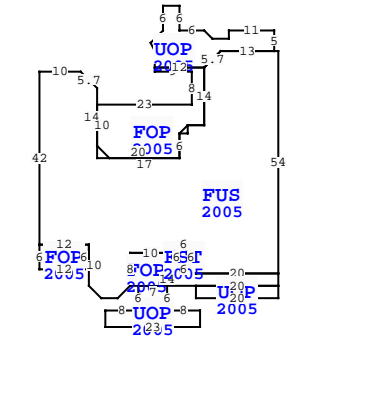
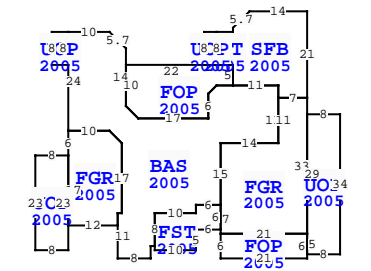

** This building has 20 Sub-Areas
38 OCEAN CLUB DR, FERNANDINA BEACH

BLD DATE	LGL DATE
XF DATE	LAND DATE
INC DATE	AG DATE

Quality	05	Quality Level 05		
DOR CODE	0100	SINGLE FAMILY		
MAP NUM		MKT AREA 10		
NEIGHBORHOOD/LOC	10014.00			
AREA TYPE	TOTAL GROSS AREA	PCT OF BASE	TOT ADJ AREA	SUBAREA MARKET VALUE
BAS	1,188	100	1,188	312,638
FGR	292	55	161	42,369
FGR	539	55	296	77,897
FOP	72	30	22	5,789
FOP	126	30	38	10,000
FOP	164	30	49	12,895
FOP	288	30	86	22,632
FOP	330	30	99	26,053
FST	36	55	20	5,263
FST	126	55	69	18,158
TOTALS	6,747		4,792	1,261,078

EXTRA FEATURES																	
L N	OB/XF CODE	DESCRIPTION	BLD CAP	L	W	UNITS	UT	Adj R	ADJ UNIT PRICE	ORIG COND	YEAR ON	YEAR ACTUAL	Q	% COND	OB/XF MKT VALUE	NOTES	
1	0410	ELEVATOR	0	100	0	0		1.00	UT	20,000.00	20,000.00	100	2005	2005	3	100	20,000
2	0810	CONCRETE A	0	100	0	0		16.00	SF	6.50	6.50	100	2005	2005	3	87	90
3	0600	SUMMER KIT	0	100	0	0		1.00	UT	5,000.00	5,000.00	100	2005	2005	3	27	1,350
4	0504	FP-ELECTRI	0	100	0	0		1.00	UT	2,000.00	2,000.00	100	2005	2005	3	90	1,800
5	0855	CONC PAVER	0	100	0	0		1,960.00	SF	10.00	10.00	100	2005	2005	3	87	17,052
6	1126	CB/STC 8"	0	100	0	0		343.00	SF	8.00	8.00	100	2005	2005	3	87	2,387
7	1242	WD DECK A	0	100	0	0		60.00	SF	10.00	10.00	100	2005	2005	3	27	162

LAND DESCRIPTION													TOTAL OB/XF												
L N	USE CODE	CLS	LAND USE DESCRIPTION	CAP	R D	LOC ZONE	FRONT	DEPTH	TOT LND UTS	UNIT TYPE	D T	DPH FACT	% COND	TOT ADJ	UNIT PRICE	ADJ UNIT PRICE	LAND VALUE	OTHER ADJUSTMENTS AND NOTES	YEAR	DENSITY	DECL	FRZ	YR	CONSRV	
1	000100	C	SFR				0.00	0.00	1.00	LT		1.00	1.00	0.90	1,000,000.00	900,000.00	900,000								

NASSAU COUNTY PROPERTY				PAGE 1 of 1	5
VALUATION SUMMARY					
VALUATION BY			STANDARD		
Tax Group: 5		Tax Dist:			
BUILDING MARKET VALUE			1,261,078		
TOTAL MARKET OB/XF VALUE			42,841		
TOTAL LAND VALUE - MARKET			900,000		
TOTAL MARKET VALUE			2,203,919		
SOH/AGL Deduction			527,716		
ASSESSED VALUE			1,676,203		
TOTAL EXEMPTION VALUE			HX HB WX 55,000		
BASE TAXABLE VALUE			1,621,203		
TOTAL JUST VALUE			2,203,919		
NCON VALUE			0		
INCOME VALUE					
PREVIOUS YEAR MKT VALUE			2,413,808		

PERMIT NUM	DESCRIPTION	AMT	ISSUED
B0412935	NEW CONSTR	625,000	06/01/2004
R046243	REPAIR/RRF	10,000	06/01/2004
E0412810	NEW CONSTR	2,000	05/01/2004
B0412663	FOUNDATION	4,500	04/01/2004

SALES DATA						
OFF RECORD Number	DATE	TYPE INST	Q U	V I	RSN CD	SALE PRICE
1815/1763	9/21/2012	WD Q	Q	I	02	1,700,000
GRANTOR: SHEFFIELD GEORGE W SR						
GRANTEE: AMOS WILLIAM L JR &						
1218/1187	3/29/2004	TD U	V	01		100
GRANTOR: SHEFFIELD BARBARA A T						
GRANTEE: SHEFFIELD GEORGE SR						

BUILDING NOTES												
----------------	--	--	--	--	--	--	--	--	--	--	--	--

BUILDING DIMENSIONS												
FUS=[YR=2005;ORIG=0,70] W1 W13 D4L4 S14 W4 D2L2 S6 W17 U3L3 N14 U4L4 W10 S42 E12 S10 D3R3 E4 U3R3 N8 E10 N2 E6 S7 E20 N54 \$												
BAS=[YR=2005;ORIG=0,0] N3 W11 W4 D2L2 S6 W17 U3L3 N14 U4L4 W10 S24 E10 D3R3 S17 W1 S11 E8 N3 E1 N8 E10 N2 E6 N15 E14 N11 \$												
FGR=[YR=2005;ORIG=-14,26] S7 E21 N33 W7 S11 W14 S15 \$												
SPB=[YR=2005;ORIG=0,0] E7 N21 W14 D4L4 S14 E11 S3 \$												
FGR=[YR=2005;ORIG=-51,8] S6 S17 E12 N3 E1 N17 U3L3 W10 \$												
FOP=[YR=2005;ORIG=-11,-3] N5 W4 W22 S10 D3R3 E17 N6 U2R2 E4 \$												
FOP=[YR=2005;ORIG=-18,74] W12 S1 E9 S8 W23 S10 S3 E20 N6 E2 N2 E4 N14 \$												