

BUILDING CHARACTERISTICS	
ELEMENT	CD
Exterior Wall	10 ABOVE AVG 100
Roof Structur	03 GABLE/HIP 100
Roof Cover	03 COMP SHNGL 100
Interior Wall	05 DRYWALL 100
Interior Floor	12 HARDWOOD 50
Interior Floor	14 CARPET 50
Air Condition	03 CENTRAL 100
Heating Type	04 AIR DUCTED 100
Bedrooms	3 100
Bathrooms	3.5 100
Frame	02 WOOD FRAME 100
Stories	2. 2. 100
Units	0 100
BUD8 Adjustme	05 DIST 1A 100
Occupancy	00 NONE 100

MARKET ADJUSTMENTS												
TYPE	MDL	EFF. AREA	TOT ADJ PTS	EFF. BASE RATE	REPL. COST NEW	AYB	EYB	ECON	FNCT	NORM	% COND	
1	SFR CUST	- 100%	- 2006									
					Heated Area: 2609			HX Base Yr 2006				

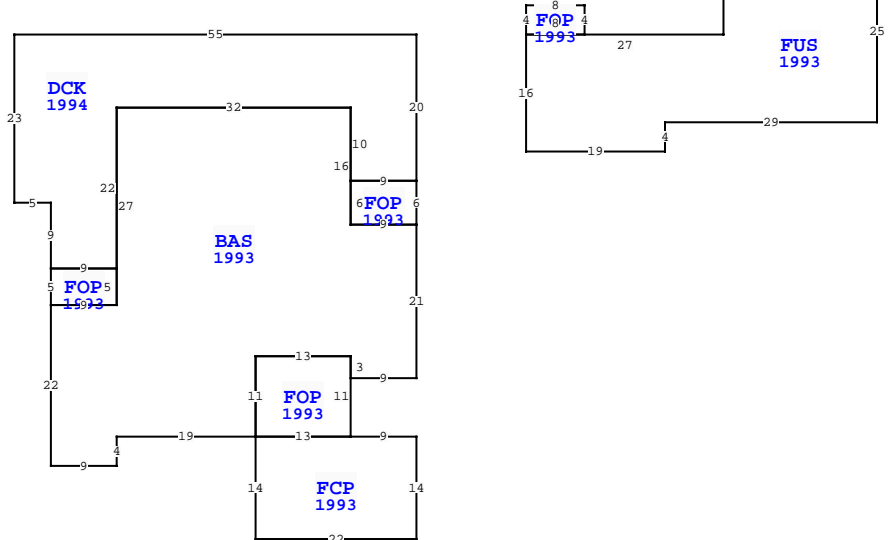

Quality	03 Quality Level 03			
DOR CODE	0100 SINGLE FAMILY			
MAP NUM	MKT AREA 10			
NEIGHBORHOOD/LOC	10001.00			
AREA TYPE	TOTAL GROSS AREA	PCT OF BASE	TOT ADJ AREA	SUBAREA MARKET VALUE
BAS	1,684	100	1,684	212,526
DCK	903	10	90	11,358
FCP	308	25	77	9,718
FOP	32	30	10	1,262
FOP	45	30	14	1,767
FOP	54	30	16	2,019
FOP	56	30	17	2,146
FOP	143	30	43	5,427
FUS	925	100	925	116,737
TOTALS	4,150		2,876	362,959

EXTRA FEATURES																
L N	OB/XF CODE	DESCRIPTION	BLD CAP	L	W	UNITS	UT	Adj R	ADJ UNIT PRICE	ORIG COND	YEAR ON	YEAR ACTUAL	Q	% COND	OB/XF MKT VALUE	NOTES
1	0812	CONCRETE C	0	100	0	1,080.00	SF	4.00	4.00	100	1984	1984	3	47	2,030	
2	0504	FP-ELECTRI	0	100	0	1.00	UT	2,000.00	2,000.00	100	1984	1984	3	58	1,160	

TOTAL OB/XF													
													3,190

LAND DESCRIPTION																							
L N	USE CODE	CLS	LAND USE DESCRIPTION	CAP	R D	LOC ZONE	FRONT	DEPTH	TOT LND UTS	UNIT TYPE	DPTH FACT	% COND	TOT ADJ	UNIT PRICE	ADJ UNIT PRICE	LAND VALUE	OTHER ADJUSTMENTS AND NOTES	YEAR	DENSITY	DECL	FRZ	YR	CONSRV
1	000140	C	SFR GOLF A	100		RS-1	0.00	0.00	1.00	LT	1.00	1.00	0.90	600,000.00	540,000.00	540,000							

TOTAL OB/XF													
													3,190

NASSAU COUNTY PROPERTY			
VALUATION SUMMARY			PAGE 1 of 1
VALUATION BY		STANDARD	
Tax Group: 5	Tax Dist:		
BUILDING MARKET VALUE			362,959
TOTAL MARKET OB/XF VALUE			3,190
TOTAL LAND VALUE - MARKET			540,000
TOTAL MARKET VALUE			906,149
SOH/AGL Deduction			486,159
ASSESSED VALUE			419,990
TOTAL EXEMPTION VALUE	HX HB	50,000	
BASE TAXABLE VALUE			369,990
TOTAL JUST VALUE			906,149
NCON VALUE			0
INCOME VALUE			
PREVIOUS YEAR MKT VALUE			631,132

PERMIT NUM	DESCRIPTION	AMT	ISSUED

SALES DATA						
OFF RECORD Number	DATE	TYPE INST	Q U	V I	RSN CD	SALE PRICE
1292/1310	2/03/2005	WD	Q	I		434,000
GRANTOR: NORDMANN WM E						
GRANTEE: STYERS JESSICA A						
0829/0331	4/08/1998	WD	Q	I		215,000
GRANTOR: FOSTER KURT						
GRANTEE: NORDMANN WM E & MAR						

BUILDING NOTES												

BUILDING DIMENSIONS												
DCK=[YR=1994] W55 S23 E5 S9 FOP=[YR=1993] S5 BAS=[YR=1993] S22 E9 N4 E19 FCP=[YR=1993] S14E22 N14 W9 FOP=[YR=1993] N11 W13 S11 E13\$ W13\$ N11 E13 S3 E9 N21 FOP=[YR=1993] N6 W9 S6 E9\$W9N16 W32 S27 W9 \$ E9 N5 W9\$ E9 N22 E32 S10 E9 N20 \$ PTR=E15 FUS=[YR=1993] E27 N13 E13 FOP=[YR=1993] N7E8 S7 W8\$ E8 S25 W29 S4 W19 N16\$ FOP=[YR=1993] E8 N4 W8 S4\$ W15\$.												