

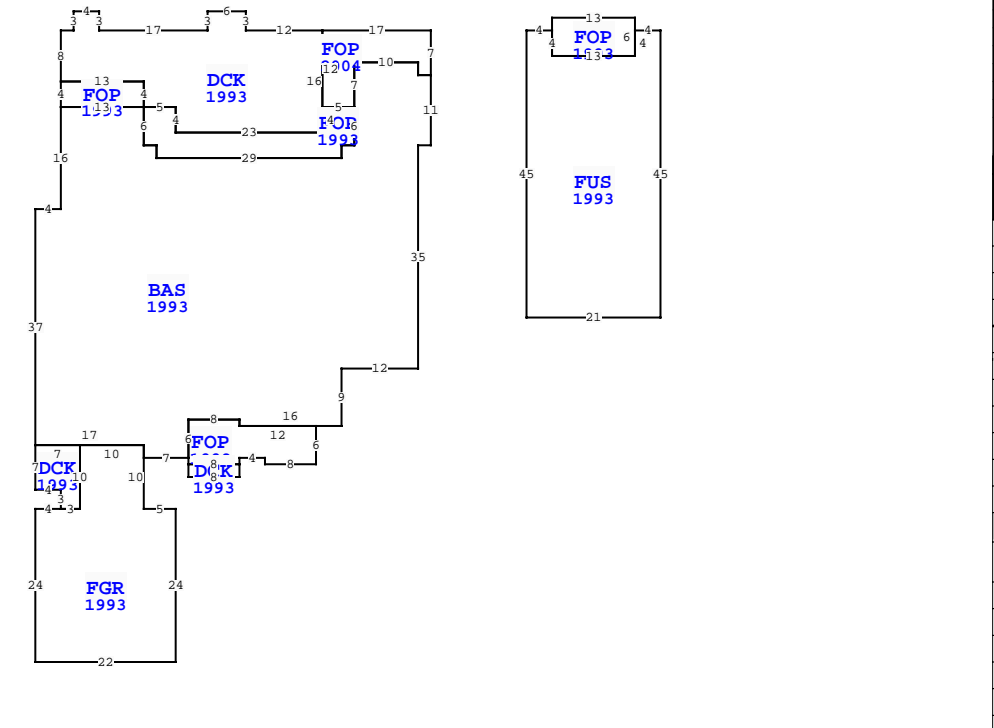

BUILDING CHARACTERISTICS	
ELEMENT	CD
Exterior Wall	16 WD FR STUC 100
Roof Structur	03 GABLE/HIP 100
Roof Cover	03 COMP SHNGL 100
Interior Wall	05 DRYWALL 100
Interior Floo	14 CARPET 70
Interior Floo	11 CLAY TILE 30
Air Condition	03 CENTRAL 100
Heating Type	04 AIR DUCTED 100
Bedrooms	3 100
Bathrooms	3.5 100
Frame	02 WOOD FRAME 100
Stories	2. 2. 100
Units	0 100
Occupancy	00 NONE 100

MARKET ADJUSTMENTS												
TYPE	MDL	EFF. AREA	TOT ADJ PTS	EFF. BASE RATE	REPL. COST NEW	AYB	EYB	ECON	FNCT	NORM	% COND	
0500	01	4,206	97.5920	139.07	584,928	1991	1991	0	0	0 15.50	84.50	

NASSAU COUNTY PROPERTY		PAGE 1 of 1	5
VALUATION SUMMARY			
VALUATION BY		STANDARD	
Tax Group: 5		Tax Dist:	
BUILDING MARKET VALUE		494,264	
TOTAL MARKET OB/XF VALUE		28,887	
TOTAL LAND VALUE - MARKET		1,050,000	
TOTAL MARKET VALUE		1,573,151	
SOH/AGL Deduction		971,652	
ASSESSED VALUE		601,499	
TOTAL EXEMPTION VALUE		HX HB 50,000	
BASE TAXABLE VALUE		551,499	
TOTAL JUST VALUE		1,573,151	
NCON VALUE		0	
INCOME VALUE			
PREVIOUS YEAR MKT VALUE		847,912	



Quality	03	Quality Level 03
DOR CODE	0100	SINGLE FAMILY
MAP NUM		MKT AREA 10
NEIGHBORHOOD/LOC	10001.00	
AREA TYPE	TOTAL GROSS AREA	PCT OF BASE
BAS	2,742	100
DCK	16	10
DCK	58	10
DCK	562	10
FGR	628	55
FOP	52	30
FOP	78	30
FOP	124	30
FOP	164	30
FOP	124	30
TOTALS	5,441	4,206

** This building has 11 Sub-Areas
9 PAINTED BUNTING, FERNANDINA BEACH

BLD DATE	LGL DATE
XF DATE	LAND DATE
INC DATE	AG DATE

PERMIT NUM	DESCRIPTION	AMT	ISSUED
M014949	H/AC	0	03/01/2001
6849	NEW CONSTR	5,400	08/08/1990

SALES DATA						
OFF RECORD Number	DATE	TYPE INST	Q / U	V / I	RSN CD	SALE PRICE
2624/1465	3/08/2023	WD	U	I	11	100

GRANTOR: MACDONALD VIRGINIA W
GRANTEE: MACDONALD VIRGINIA
0674/0852 1/28/1993 WD Q I 485,000
GRANTOR: ANDERSON RONALD & ME
GRANTEE: MACDONALD RALPH JR

BUILDING NOTES	

L N	OB/XF CODE	DESCRIPTION	BLD	CAP	L	W	UNITS	UT	Adj R	ADJ UNIT PRICE	ORIG COND	YEAR ON	YEAR ACTUAL	Q	% COND	OB/XF MKT VALUE	NOTES
1	0504	FP-ELECTRI	0	100	0	0	1.00	UT	2,000.00	2,000.00	100	1991	1991	3	72	1,440	
2	1126	CB/STC 8"	0	100	0	0	741.00	SF	8.00	8.00	100	1991	1991	3	64	3,794	
4	0861	POOL GUNIT	0	100	0	0	207.00	SF	85.00	85.00	100	2004	2004	3	40	7,038	
5	0845	KOOL DECK	0	100	0	0	421.00	SF	7.25	7.25	100	2004	2004	3	86	2,625	
6	0910	SCRN RM L	0	100	0	0	623.00	SF	15.00	15.00	100	2004	2004	3	24	2,243	
7	1126	CB/STC 8"	0	100	0	0	214.00	SF	8.00	8.00	100	2004	2004	3	86	1,472	
8	0855	CONC PAVER	0	100	0	0	1,668.00	SF	7.00	7.00	100	2006	2006	3	88	10,275	

BUILDING DIMENSIONS	
FOP=[YR=2004] W17 DCK=[YR=1993] W12 N3 W6 S3 W17 N3 W4 S3 W2 S8 FOP=[YR=1993] S4 BAS=[YR=1993] S16 W4 S37 DCK=[YR=1993] S7 E4 S3 FGR=[YR=1993] W4 S24 E22 N24 W5 N10 W10 S10 W3 \$ E3 N10 W7 \$ E17 S2 E7 FOP=[YR=1993] S1 DCK=[YR=1993] S2 E8 N2 W8 \$ E8 N1 E4 S1 E8 N6 W12 N1 W8 S6 \$ N6 E8 S1 E16 N9 E12 N35 E2 N11 W2 N2 W10 S7 FOP=[YR=1993] S6 W2 S2 W29 N2 W2 N6 E5 S4 E23 N4 E5 \$ S6 W2 S2 W29 N2 W2 N6 W13 \$ E13 N4 W13 \$ E13 S4 E5 S4 E23 N16 \$ S12 E5 N7 E10 S2 E2 N7 \$ PTR= E15 FUS=[YR=1993] E4 FOP=[YR=1993] N2 E13 S6 W13 N4 \$ S4 E13 N4 E4 S45 W21 N45 \$ W15 \$.	

LAND DESCRIPTION		TOTAL OB/XF 28,887																						
L N	USE CODE	CLS	LAND USE DESCRIPTION	CAP	R D	LOC ZONE	FRONT	DEPTH	TOT LND UTS	UNIT TYPE	D T	DPH FACT	% COND	TOT ADJ	UNIT PRICE	ADJ UNIT PRICE	LAND VALUE	OTHER ADJUSTMENTS AND NOTES	YEAR	DENSITY	DECL	FRZ	YR	CONSRV
1	000140	C	SFR GOLF A	100		RS-1	0.00	0.00	1.00	LT		1.00	1.00	1.00	600,000.00	600,000.00	600,000							
2	000100	C	SFR	100			0.00	0.00	1.00	LT		1.00	1.00	1.00	450,000.00	450,000.00	450,000							