

BUILDING CHARACTERISTICS		CONSTRUCTION	
ELEMENT	CD		
Exterior Wall	12	CEDAR 100	
Roof Structur	03	GABLE/HIP 100	
Roof Cover	03	COMP SHNGL 100	
Interior Wall	05	DRYWALL 50	
Interior Wall	08	DECORATIVE 50	
Interior Floor	11	CLAY TILE 50	
Interior Floor	14	CARPET 50	
Air Condition	03	CENTRAL 100	
Heating Type	04	AIR DUCTED 100	
Bedrooms		3 100	
Bathrooms		2.5 100	
Frame	02	WOOD FRAME 100	
Stories	1.	1. 100	
Units		0 100	
BUD8 Adjustme	02	DIST FB 100	
Occupancy	00	NONE 100	
Quality	03	Quality Level 03	
DOR CODE	0100	SINGLE FAMILY	
MAP NUM		MKT AREA	01
NEIGHBORHOOD/LOC	1044.00		
AREA TYPE	TOTAL GROSS AREA	PCT OF BASE	TOT ADJ AREA
BAS	2,920	100	2,920
DCK	96	10	10
FGR	528	55	290
FOP	40	30	12
FOP	280	30	84
TOTALS	3,864		3,316
			352,687

MARKET ADJUSTMENTS												
TYPE	MDL	EFF. AREA	TOT ADJ PTS	EFF. BASE RATE	REPL. COST NEW	AYB	EYB	ECON	FNCT	NORM	% COND	
0900	01	3,316	108.5600	128.92	427,499	1987	1987	0	0	17.50	82.50	
1 SNGL FAM - 100% - 0 Heated Area: 2920 HX Base Yr												

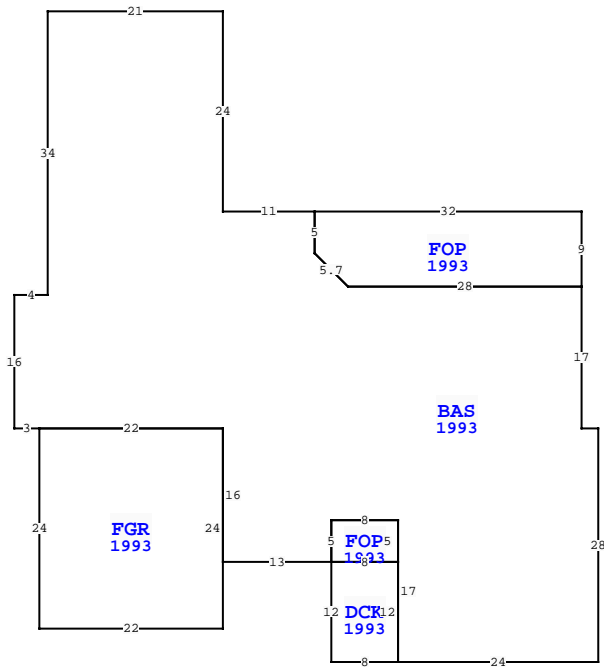

NASSAU COUNTY PROPERTY		PAGE 1 of 2
VALUATION SUMMARY		
VALUATION BY		STANDARD
Tax Group: 2	Tax Dist:	
BUILDING MARKET VALUE		352,687
TOTAL MARKET OB/XF VALUE		23,672
TOTAL LAND VALUE - MARKET		720,000
TOTAL MARKET VALUE		1,096,359
SOH/AGL Deduction		778,019
ASSESSED VALUE		318,340
TOTAL EXEMPTION VALUE	HX HB VX WR	60,000
BASE TAXABLE VALUE		258,340
TOTAL JUST VALUE		1,096,359
NCON VALUE		0
INCOME VALUE		
PREVIOUS YEAR MKT VALUE		1,076,626

PERMIT NUM	DESCRIPTION	AMT	ISSUED
20121393	ROOF	8,000	07/13/2012
20110018	H/AC	5,300	01/04/2011
20080159	XFOB	900	02/04/2008
BP4123	N/A	180,000	01/20/1987

SALES DATA						
OFF RECORD Number	DATE	TYPE INST	Q / U	V / I	RSN CD	SALE PRICE
1746/1597	7/05/2011	WD U	I	I	30	100
GRANTOR: MURPHY GEORGE M & BJO						
GRANTEE: MURPHY GEORGE M & B						
1746/1595	7/05/2011	WD U	I	I	30	100
GRANTOR: MURPHY GEORGE M & BJO						
GRANTEE: MURPHY GEORGE M						

EXTRA FEATURES																
L N	OB/XF CODE	DESCRIPTION	BLD CAP	L	W	UNITS	UT	Adj R	ADJ UNIT PRICE	ORIG COND	YEAR ON	YEAR ACTUAL	Q	% COND	OB/XF MKT VALUE	NOTES
1	0820	WOOD WALK	0 100	40	4	160.00	SF	11.75	11.75	100	1987	1987	3	40	752	
2	0861	POOL GUNIT	0 100	31	16	496.00	SF	85.00	85.00	100	1987	1987	3	20	8,432	
3	0812	CONCRETE C	0 100	0	0	2,034.00	SF	4.00	4.00	100	1987	1987	3	54.5	4,434	
4	0504	FP-ELECTRI	0 100	0	0	1.00	UT	2,000.00	2,000.00	100	1987	1987	3	64	1,280	
5	0845	KOOL DECK	0 100	0	0	624.00	SF	7.25	7.25	100	1987	1987	3	54.5	2,466	
6	1242	WD DECK A	0 100	0	0	232.00	SF	10.00	10.00	100	1987	1987	3	20	464	
7	1242	WD DECK A	0 100	48	4	192.00	SF	10.00	10.00	100	1989	1989	3	20	384	
8	1242	WD DECK A	0 100	0	0	85.00	SF	10.00	10.00	100	1989	1989	3	20	170	
9	1242	WD DECK A	0 100	0	0	85.00	SF	10.00	10.00	100	1989	1989	3	20	170	
10	1242	WD DECK A	0 100	8	3	24.00	SF	10.00	10.00	100	1989	1989	3	20	48	

TOTAL OB/XF																								
18,600																								
L N	USE CODE	CLS	LAND USE DESCRIPTION	CAP	R D	LOC ZONE	FRONT	DEPTH	TOT LND UTS	UNIT TYPE	D T	DPTH FACT	% COND	TOT ADJ	UNIT PRICE	ADJ UNIT PRICE	LAND VALUE	OTHER ADJUSTMENTS AND NOTES	YEAR	DENSITY	DECL	FRZ	YR	CONSRV
1	000100	C	SFR	100		R-1A	180.00	160.00	180.00	FF		1.00	1.00	1.00	4,000.00	4,000.00	720,000							

BUILDING NOTES												
BLD DATE												
XF DATE												
INC DATE												
LGL DATE												
LAND DATE												
AG DATE												

BUILDING DIMENSIONS												
FOP=[YR=1993] W32 BAS=[YR=1993] W11 N24 W21 S34 W4 S16 E3												
FGR=[YR=1993] S24 E22 N24 W22\$ E22 S16 E13 DCK=[YR=1993] S12												
E8 N12 W8\$ FOP=[YR=1993] E8 N5 W8 S5\$ N5 E8 S17 E24 N28 W2												
N17 W28 U4 L4 N5\$ S5 R4 D4 E28 N9\$.												

REVIEW DATE 08/20/2019 BY DJA																													
Total Acres: 0.00										Total Land Value: 720,000					Market: 0					Agricultural: 0					Common: 720,000				

