

BUILDING CHARACTERISTICS		
ELEMENT	CD	CONSTRUCTION
Exterior Wall	10	ABOVE AVG 100
Roof Structur	03	GABLE/HIP 100
Roof Cover	03	COMP SHNGL 100
Interior Wall	05	DRYWALL 100
Interior Floor	14	CARPET 80
Interior Floor	11	CLAY TILE 20
Air Condition	03	CENTRAL 100
Heating Type	04	AIR DUCTED 100
Bedrooms		3 100
Bathrooms		2.5 100
Frame	02	WOOD FRAME 100
Stories	3.	3. 100
Units		0 100
Occupancy	00	NONE 100

MARKET ADJUSTMENTS												
TYPE	MDL	EFF. AREA	TOT ADJ PTS	EFF. BASE RATE	REPL. COST NEW	AYB	EYB	ECON	FNCT	NORM	% COND	
0900	01	2,651	107.1360	127.22	337,260	2001	2001	0	0	10.00	90.00	

1 SNGL FAM - 0% - 0 Heated Area: 2140 HX Base Yr

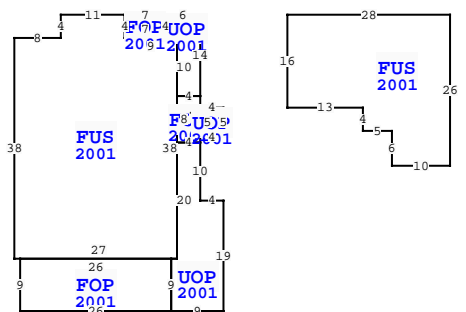
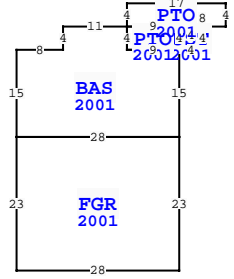

Quality	03	Quality Level 03		
DOR CODE	0100	SINGLE FAMILY		
MAP NUM		MKT AREA 01		
NEIGHBORHOOD/LOC	1044.00			
AREA TYPE	TOTAL GROSS AREA	PCT OF BASE	TOT ADJ AREA	SUBAREA MARKET VALUE
BAS	464	100	464	53,127
FGR	644	55	354	40,532
FOP	28	30	8	916
FOP	32	30	10	1,145
FOP	234	30	70	8,015
FUS	568	100	568	65,035
FUS	1,108	100	1,108	126,864
PTO	36	5	2	229
PTO	68	5	3	344
UOP	20	20	4	458
TOTALS	3,483		2,651	303,534

** This building has 13 Sub-Areas
3611 1ST AVE, FERNANDINA BEACH

BLD DATE	LGL DATE
XF DATE	LAND DATE
INC DATE	AG DATE

NASSAU COUNTY PROPERTY		
VALUATION SUMMARY		PAGE 1 of 1
VALUATION BY	STANDARD	
Tax Group: 2	Tax Dist:	
BUILDING MARKET VALUE	303,534	
TOTAL MARKET OB/XF VALUE	8,218	
TOTAL LAND VALUE - MARKET	360,000	
TOTAL MARKET VALUE	671,752	
SOH/AGL Deduction	151,210	
ASSESSED VALUE	520,542	
TOTAL EXEMPTION VALUE	0	
BASE TAXABLE VALUE	520,542	
TOTAL JUST VALUE	671,752	
NCON VALUE	0	
INCOME VALUE	0	
PREVIOUS YEAR MKT VALUE	614,540	

PERMIT NUM	DESCRIPTION	AMT	ISSUED
B0003661	NEW CONSTR	195,000	08/09/2000
B0003401	FOUNDATION	2,500	07/03/2000

SALES DATA						
OFF RECORD Number	DATE	TYPE INST	Q / U	V / I	RSN CD	SALE PRICE
2272/1065	5/03/2019	WD U	U	I	30	450,000
GRANTOR: HALLETT HOWARD D L/E						
GRANTEE: HALLET STEPHEN & LA						
2025/0233	1/21/2016	LE U	I	11		100
GRANTOR: HALLETT HOWARD D						
GRANTEE: HALLETT HOWARD D L/						

BUILDING NOTES	

BUILDING DIMENSIONS	
UOP=[YR=2001] W6 FOP=[YR=2001] W7 FUS=[YR=2001] W11 S4 W8 S38 E1 FOP=[YR=2001] S9 E26 UOP=[YR=2001] E9 N19 W4 N10 FOP=[YR=2001] N1 UOP=[YR=2001] E4 N5 W4 S5 \$ N7 W4 S8 E4 \$ W4 S20 W1 S9 \$ N9 W26 \$ E27 N38 W9 N4 \$ S4 E7 N4 \$ S4 E2 S10 E4 N14 \$ PTR= E15 FUS=[YR=2001] E28 S26 W10 N6 W5 N4 W13 N16 \$ W15 \$ PTR= N15 FGR=[YR=2001] N23 BAS=[YR=2001] N15 UST=[YR=2001] E4 N4 W4 S4 \$ PTO=[YR=2001] N4 PTO=[YR=2001] E8 N4 W17 S4 E9 \$ W9 S4 E9 \$ W9 N4 W11 S4 W8 S15 E28 \$ W28 S23 E28 \$ S15 \$.	

EXTRA FEATURES																	
L N	OB/XF CODE	DESCRIPTION	BLD	CAP	L	W	UNITS	UT	Adj R	ADJ UNIT PRICE	ORIG COND	YEAR ON	YEAR ACTUAL	Q	% COND	OB/XF MKT VALUE	NOTES
1	0500	FP-PRE FAB	0	0	0	0	1.00	UT	3,500.00	3,500.00	100	2001	2001	3	86	3,010	
2	0811	CONCRETE B	0	0	0	0	890.00	SF	5.20	5.20	100	2001	2001	3	82	3,795	
3	0810	CONCRETE A	0	0	58	4	232.00	SF	6.50	6.50	100	2001	2001	3	82	1,237	
4	1242	WD DECK A	0	0	0	0	88.00	SF	10.00	10.00	100	2001	2001	3	20	176	

LAND DESCRIPTION													TOTAL OB/XF											
L N	USE CODE	CLS	LAND USE DESCRIPTION	CAP	R D	LOC ZONE	FRONT	DEPTH	TOT LND UTS	UNIT TYPE	D T	DPH FACT	% COND	TOT ADJ	UNIT PRICE	ADJ UNIT PRICE	LAND VALUE	OTHER ADJUSTMENTS AND NOTES	YEAR	DENSITY	DECL	FRZ	YR	CONSRV
1	000100	C	SFR	0			50.00	100.00	100.00	FF		1.00	1.00	0.80	4,500.00	3,600.00	360,000							