

BLOCK 4 LOTS 1 2 3 N3/4 OF
 LOT 4 N3/4 OF LOT 29 E 35
 FT OF LOTS 30 31 32

HABIG BARBARA J
 3580 S FLETCHER AVE
 FERNANDINA BEACH, FL 32034

2023

00-00-31-1680-0004-0010

BUILDING CHARACTERISTICS	
ELEMENT	CD CONSTRUCTION
Exterior Wall	16 WD FR STUC 60
Exterior Wall	10 ABOVE AVG 40
Roof Structure	03 GABLE/HIP 100
Roof Cover	03 COMP SHNGL 100
Interior Wall	05 DRYWALL 90
Interior Wall	08 DECORATIVE 10
Interior Floor	12 HARDWOOD 60
Interior Floor	14 CARPET 40
Air Condition	03 CENTRAL 100
Heating Type	04 AIR DUCTED 100
Bedrooms	3 100
Bathrooms	2.5 100
Frame	02 WOOD FRAME 100
Stories	2. 100
Units	0 100
BUD8 Adjustme	02 DIST FB 100

MARKET ADJUSTMENTS												
TYPE	MDL	EFF. AREA	TOT ADJ PTS	EFF. BASE RATE	REPL. COST NEW	AYB	EYB	ECON	FNCT	NORM	% COND	
0500	11	3,844	128.8980	183.68	706,066	1968	2000	0	0	10.80	89.20	
1 SFR CUST - 100% - 2022 Heated Area: 3396 HX Base Yr 2022												

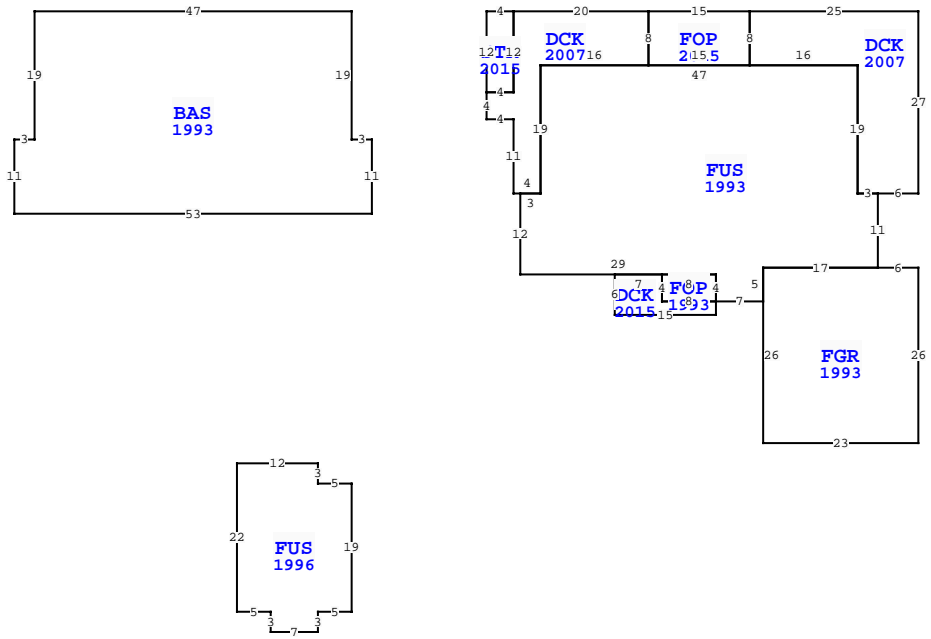

Quality				
DOR CODE	MAP NUM			
04	01			
0100 SINGLE FAMILY				
1053.00				
AREA TYPE	TOTAL GROSS AREA	PCT OF BASE	TOT ADJ AREA	SUBAREA MARKET VALUE
BAS	1,476	100	1,476	241,832
DCK	252	10	25	4,096
DCK	371	10	37	6,062
DCK	58	10	6	983
FGR	598	55	329	53,904
FOP	32	30	10	1,639
FOP	120	30	36	5,898
FUS	1,540	100	1,540	252,317
FUS	380	100	380	62,260
STR	48	10	5	819
TOTALS	4,875		3,844	629,811

EXTRA FEATURES																
L N	OB/XF CODE	DESCRIPTION	BLD CAP	L	W	UNITS	UT	Adj R	ADJ UNIT PRICE	ORIG COND	YEAR ON	YEAR ACTUAL	Q	% COND	OB/XF MKT VALUE	NOTES
1	0812	CONCRETE C	0	100	0	1,725.00	UT	4.00	4.00	100	1993	1993	3	68	4,692	
2	0504	FP-ELECTRI	0	100	0	1.00	UT	2,000.00	2,000.00	100	1993	1993	3	76	1,520	
3	0861	POOL GUNIT	0	100	38	494.00	SF	85.00	85.00	100	1993	1993	3	20	8,398	
4	0845	KOOL DECK	0	100	0	1,388.00	SF	7.25	7.25	100	2015	2015	3	96	9,660	
5	0415	BEACHWALK	0	100	278	1,112.00	SF	5.75	5.75	100	1995	1995	3	20	1,279	

TOTAL OB/XF																
L N	OB/XF CODE	DESCRIPTION	BLD CAP	L	W	UNITS	UT	Adj R	ADJ UNIT PRICE	ORIG COND	YEAR ON	YEAR ACTUAL	Q	% COND	OB/XF MKT VALUE	NOTES
3580 S FLETCHER AVE, FERNANDINA BEACH																
25,549																

LAND DESCRIPTION																							
L N	USE CODE	CLS	LAND USE DESCRIPTION	CAP	R D	LOC ZONE	FRONT	DEPTH	TOT LND UTS	UNIT TYPE	D T	% COND	TOT ADJ	UNIT PRICE	ADJ UNIT PRICE	LAND VALUE	OTHER ADJUSTMENTS AND NOTES	YEAR	DENSITY	DECL	FRZ	YR	CONSRV
1	000120	C	SFR OCN FT	100			93.00	400.00	93.00	FF	3	1.18	1.18	14,000.00	16,520.00	1,536,360							

TOTAL OB/XF																
L N	OB/XF CODE	DESCRIPTION	BLD CAP	L	W	UNITS	UT	Adj R	ADJ UNIT PRICE	ORIG COND	YEAR ON	YEAR ACTUAL	Q	% COND	OB/XF MKT VALUE	NOTES
3580 S FLETCHER AVE, FERNANDINA BEACH																
25,549																

NASSAU COUNTY PROPERTY		PAGE 1 of 1	2
VALUATION SUMMARY			
VALUATION BY		STANDARD	
Tax Group: 2		Tax Dist:	
BUILDING MARKET VALUE		629,811	
TOTAL MARKET OB/XF VALUE		25,549	
TOTAL LAND VALUE - MARKET		1,536,360	
TOTAL MARKET VALUE		2,191,720	
SOH/AGL Deduction		0	
ASSESSED VALUE		2,191,720	
TOTAL EXEMPTION VALUE		HX HB 50,000	
BASE TAXABLE VALUE		2,141,720	
TOTAL JUST VALUE		2,191,720	
NCON VALUE		0	
INCOME VALUE		0	
PREVIOUS YEAR MKT VALUE		2,164,251	

PERMIT NUM	DESCRIPTION	AMT	ISSUED
20132706	REMODEL	500	11/27/2013
B972289	REMODEL	6,000	11/21/1997
B9610039	ADDITION	28,000	09/16/1996
B969800	REMODEL	3,000	05/06/1996
B8962	XFOB	2,500	03/30/1995
7778	SWIM POOL	10,000	06/30/1993

SALES DATA						
OFF RECORD Number	DATE	TYPE INST	Q U	V I	RSN CD	SALE PRICE
1860/1174	6/05/2013	WD	Q	I	02	1,616,700
GRANTOR: FELLONA JJOSEPH L JR						
GRANTEE: HABIG BARBARA J						
1077/0707	8/27/2002	WD	U	I	07	100
GRANTOR: FELLONA JOSEPH L JR &						
GRANTEE: FELLONA JOSEPH JR &						

BUILDING NOTES												

BUILDING DIMENSIONS												
BAS=[YR=1993] W47 S19 W3 S11 E53 N11 W3 N19\$ PTR=E20												
STR=[YR=2015] E4 DCK=[YR=2007] E20 FOP=[YR=2015] E15												
DCK=[YR=2007] E25 S27 W6 FUS=[YR=1993] S11 FGR=[YR=1993] E6												
S26 W23 N26 E17\$ W17 S5 W7DCK=[YR=2015] S2 W15 N6 E7												
FOP=[YR=1993] E8 S4 W8 N4\$ S4 E8\$ N4 W29 N12 E3 N19 E47 S19												
E3\$ W3 N19 W16 N8\$ S8 W15 N8\$ S8 W16 S19 W4 N11 W4 N4 E4 N12\$												
S12 W4 N12\$ W20\$ PTR= S70 FUS=[YR=1996] S19W5 S3 W7 N3 W5												
N22 E12 S3 E5 \$N70 \$.												