

| BUILDING CHARACTERISTICS |     |                |
|--------------------------|-----|----------------|
| ELEMENT                  | CD  | CONSTRUCTION   |
| Exterior Wall            | 10  | ABOVE AVG 100  |
| Roof Structur            | 08  | IRREGULAR 100  |
| Roof Cover               | 03  | COMP SHNGL 100 |
| Interior Wall            | 05  | DRYWALL 100    |
| Interior Floor           | 12  | HARDWOOD 80    |
| Interior Floor           | 15  | HARDTILE 20    |
| Air Condition            | 03  | CENTRAL 100    |
| Heating Type             | 04  | AIR DUCTED 100 |
| Bedrooms                 |     | 3 100          |
| Bathrooms                |     | 2.5 100        |
| Frame                    | 02  | WOOD FRAME 100 |
| Stories                  | 1.5 | 1.5 100        |
| Units                    |     | 0 100          |
| Occupancy                | 00  | NONE 100       |

| MARKET ADJUSTMENTS       |     |           |                   |                |                |                 |      |      |      |      |        |       |
|--------------------------|-----|-----------|-------------------|----------------|----------------|-----------------|------|------|------|------|--------|-------|
| TYPE                     | MDL | EFF. AREA | TOT ADJ PTS       | EFF. BASE RATE | REPL. COST NEW | AYB             | EYB  | ECON | FNCT | NORM | % COND |       |
| 0500                     | 01  | 2,920     | 119.5304          | 170.33         | 497,364        | 2006            | 2006 | 0    | 0    | 0    | 7.50   | 92.50 |
| 1 SFR CUST - 100% - 2021 |     |           | Heated Area: 2527 |                |                | HX Base Yr 2021 |      |      |      |      |        |       |

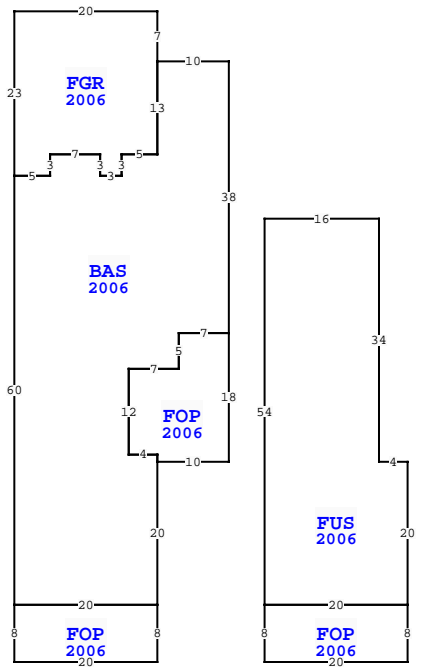

|                  |                  |                  |              |                      |
|------------------|------------------|------------------|--------------|----------------------|
| Quality          | 05               | Quality Level 05 |              |                      |
| DOR CODE         | 0100             | SINGLE FAMILY    |              |                      |
| MAP NUM          |                  | MKT AREA 01      |              |                      |
| NEIGHBORHOOD/LOC | 1031.00          |                  |              |                      |
| AREA TYPE        | TOTAL GROSS AREA | PCT OF BASE      | TOT ADJ AREA | SUBAREA MARKET VALUE |
| BAS              | 1,583            | 100              | 1,583        | 249,410              |
| FGR              | 424              | 55               | 233          | 36,710               |
| FOP              | 160              | 30               | 48           | 7,563                |
| FOP              | 160              | 30               | 48           | 7,563                |
| FOP              | 213              | 30               | 64           | 10,083               |
| FUS              | 944              | 100              | 944          | 148,733              |
| TOTALS           | 3,484            |                  | 2,920        | 460,062              |

| NASSAU COUNTY PROPERTY    |              |  | PAGE 1 of 1 | 2 |
|---------------------------|--------------|--|-------------|---|
| VALUATION SUMMARY         |              |  |             |   |
| VALUATION BY              | STANDARD     |  |             |   |
| Tax Group: 2              | Tax Dist:    |  |             |   |
| BUILDING MARKET VALUE     | 460,062      |  |             |   |
| TOTAL MARKET OB/XF VALUE  | 6,345        |  |             |   |
| TOTAL LAND VALUE - MARKET | 132,000      |  |             |   |
| TOTAL MARKET VALUE        | 598,407      |  |             |   |
| SOH/AGL Deduction         | 83,572       |  |             |   |
| ASSESSED VALUE            | 514,835      |  |             |   |
| TOTAL EXEMPTION VALUE     | HX HB 50,000 |  |             |   |
| BASE TAXABLE VALUE        | 464,835      |  |             |   |
| TOTAL JUST VALUE          | 598,407      |  |             |   |
| NCON VALUE                | 0            |  |             |   |
| INCOME VALUE              |              |  |             |   |
| PREVIOUS YEAR MKT VALUE   | 561,413      |  |             |   |

| PERMIT NUM | DESCRIPTION | AMT    | ISSUED     |
|------------|-------------|--------|------------|
| 20200670   | CO ISSUED   | 0      | 09/30/2020 |
| 20062374   | OTHER       | 2,000  | 10/23/2006 |
| 20060711   | GAS         | 800    | 04/06/2006 |
| 20060682   | H/AC        | 6,850  | 04/01/2006 |
| 20060450   | NEW CONSTR  | 2,000  | 03/06/2006 |
| 20060339   | NEW CONSTR  | 11,525 | 02/14/2006 |

| SALES DATA                     |            |           |       |       |        |            |
|--------------------------------|------------|-----------|-------|-------|--------|------------|
| OFF RECORD Number              | DATE       | TYPE INST | Q / U | V / I | RSN CD | SALE PRICE |
| 2399/1405                      | 10/09/2020 | WD        | Q     | I     | 01     | 617,000    |
| GRANTOR: SISTKO ROBERT J & LYN |            |           |       |       |        |            |
| GRANTEE: ADAMS MICHAEL THOMA   |            |           |       |       |        |            |
| 1469/0824                      | 1/04/2007  | WD        | U     | I     | 21     | 513,571    |
| GRANTOR: WATSON HOME BUILDERS  |            |           |       |       |        |            |
| GRANTEE: SISTKO ROBERT J & L   |            |           |       |       |        |            |

| EXTRA FEATURES |            |             |         |     |    |       |        |       |                |           |         |             |       |        |                 |       |
|----------------|------------|-------------|---------|-----|----|-------|--------|-------|----------------|-----------|---------|-------------|-------|--------|-----------------|-------|
| L N            | OB/XF CODE | DESCRIPTION | BLD CAP | L   | W  | UNITS | UT     | Adj R | ADJ UNIT PRICE | ORIG COND | YEAR ON | YEAR ACTUAL | Q     | % COND | OB/XF MKT VALUE | NOTES |
| 1              | 0500       | FP-PRE FAB  | 0       | 100 | 0  | 0     | 1.00   | UT    | 3,500.00       | 100       | 2006    | 2006        | 3     | 91     | 3,185           |       |
| 2              | 0877       | JACUZZI     | 0       | 100 | 0  | 0     | 1.00   | UT    | 1,000.00       | 100       | 2006    | 2006        | 3     | 31     | 310             |       |
| 5              | 0825       | BRICK       | 0       | 100 | 4  | 5     | 20.00  | SF    | 25.00          | 100       | 2006    | 2006        | 3     | 97     | 485             |       |
| 6              | 0810       | CONCRETE A  | 0       | 100 | 7  | 5     | 35.00  | SF    | 6.50           | 100       | 2006    | 2006        | 3     | 88     | 200             |       |
| 7              | 0810       | CONCRETE A  | 0       | 100 | 21 | 16    | 336.00 | SF    | 6.50           | 100       | 2006    | 2006        | 3     | 88     | 1,922           |       |
| 8              | 0825       | BRICK       | 0       | 100 | 5  | 2     | 10.00  | SF    | 25.00          | 100       | 2006    | 2006        | 3     | 97     | 243             |       |
| TOTALS         |            |             |         |     |    |       |        |       |                |           |         |             | 6,345 |        |                 |       |

| LAND DESCRIPTION |          |     |                      |     |     |          |       |       |             |           |     |          | TOTAL OB/XF |         |            |                |            |                             |      |         |      |     |    |        |
|------------------|----------|-----|----------------------|-----|-----|----------|-------|-------|-------------|-----------|-----|----------|-------------|---------|------------|----------------|------------|-----------------------------|------|---------|------|-----|----|--------|
| L N              | USE CODE | CLS | LAND USE DESCRIPTION | CAP | R D | LOC ZONE | FRONT | DEPTH | TOT LND UTS | UNIT TYPE | D T | DPH FACT | % COND      | TOT ADJ | UNIT PRICE | ADJ UNIT PRICE | LAND VALUE | OTHER ADJUSTMENTS AND NOTES | YEAR | DENSITY | DECL | FRZ | YR | CONSRV |
| 1                | 000100   | C   | SFR                  | 100 |     | PUD      | 0.00  | 0.00  | 44.00       | FF        |     | 1.00     | 1.00        | 1.00    | 3,000.00   | 3,000.00       | 132,000    |                             |      |         |      |     |    |        |