

BUILDING CHARACTERISTICS	
ELEMENT	CD
Exterior Wall	10 ABOVE AVG 100
Roof Structur	08 IRREGULAR 100
Roof Cover	03 COMP SHNGL 100
Interior Wall	05 DRYWALL 100
Interior Floo	03 CONC FINSH 60
Interior Floo	13 LVT/LAMNT 40
Air Condition	03 CENTRAL 100
Heating Type	04 AIR DUCTED 100
Bedrooms	6 100
Bathrooms	4.5 100
Frame	02 WOOD FRAME 100
Stories	2. 2. 100
Units	0 100
Occupancy	00 NONE 100

MARKET ADJUSTMENTS												
TYPE	MDL	EFF. AREA	TOT ADJ PTS	EFF. BASE RATE	REPL. COST NEW	AYB	EYB	ECON	FNCT	NORM	% COND	
0500	01	4,928	93.0520	132.60	653,453	2019	2019	0	0	0	1.00	99.00

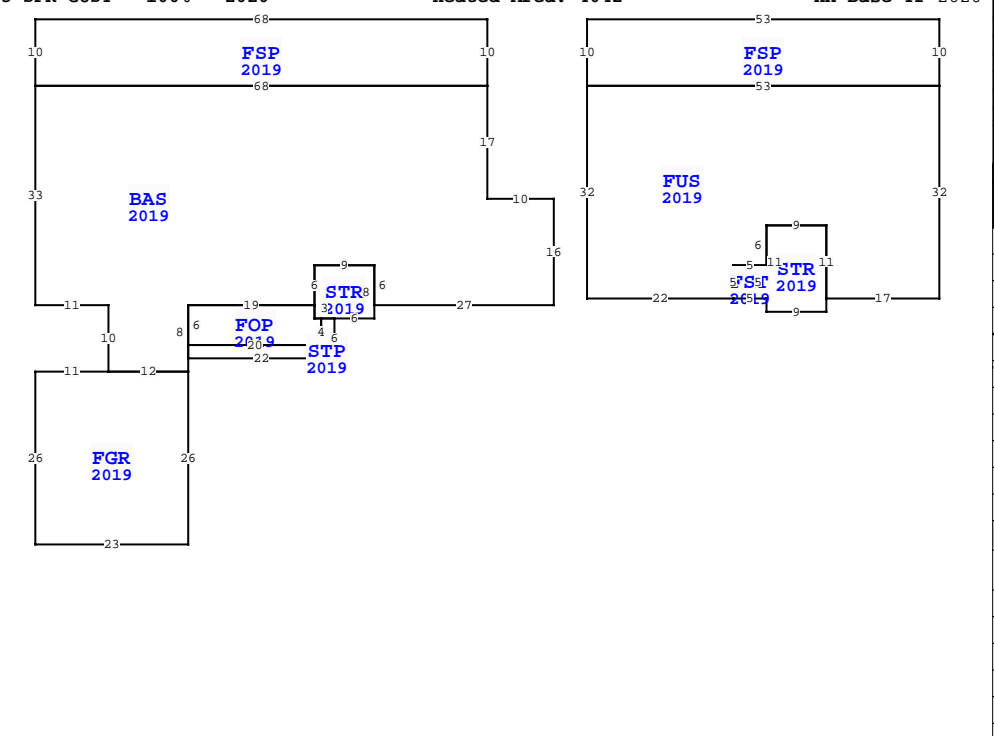

Quality	03 Quality Level 03			
DOR CODE	0100 SINGLE FAMILY			
MAP NUM	MKT AREA 02			
NEIGHBORHOOD/LOC	2020.00			
AREA TYPE	TOTAL GROSS AREA	PCT OF BASE	TOT ADJ AREA	SUBAREA MARKET VALUE
BAS	2,470	100	2,470	324,247
FGR	598	55	329	43,189
FOP	118	30	35	4,595
FSP	530	40	212	27,830
FSP	680	40	272	35,706
FST	25	55	14	1,837
FUS	1,572	100	1,572	206,363
STP	52	10	5	656
STR	72	10	7	919
STR	117	10	12	1,575
TOTALS	6,234		4,928	646,918

EXTRA FEATURES																
L N	OB/XF CODE	DESCRIPTION	BLD CAP	L	W	UNITS	UT	Adj R	ADJ UNIT PRICE	ORIG COND	YEAR ON	YEAR ACTUAL	Q	% COND	OB/XF MKT VALUE	NOTES
1	0812	CONCRETE C	0	100	0	3,062.00	SF	4.00	4.00	100	2019	2019	3	99	12,126	

TOTAL OB/XF												
12,126												

LAND DESCRIPTION																								
L N	USE CODE	CLS	LAND USE DESCRIPTION	CAP	R D	LOC ZONE	FRONT	DEPTH	TOT LND UTS	UNIT TYPE	D T	DPHT FACT	% COND	TOT ADJ	UNIT PRICE	ADJ UNIT PRICE	LAND VALUE	OTHER ADJUSTMENTS AND NOTES	YEAR	DENSITY	DECL	FRZ	YR	CONSRV
1	000100	C	SFR	100		RS-2	0.00	0.00	1.70	AC		1.00	1.00	1.00	250,000.00	250,000.00	425,000							
2	009620	C	MARSH	0			0.00	0.00	0.86	AC		1.00	1.00	1.00	100.00	100.00	86							

TOTAL OB/XF												
12,126												

NASSAU COUNTY PROPERTY		PAGE 1 of 2	8
VALUATION SUMMARY			
VALUATION BY	STANDARD		
Tax Group: 8	Tax Dist:		
BUILDING MARKET VALUE		672,128	
TOTAL MARKET OB/XF VALUE		12,126	
TOTAL LAND VALUE - MARKET		425,086	
TOTAL MARKET VALUE		1,109,340	
SOH/AGL Deduction		482,260	
ASSESSED VALUE		627,080	
TOTAL EXEMPTION VALUE	HX HB WX DX	60,000	
BASE TAXABLE VALUE		567,080	
TOTAL JUST VALUE		1,109,340	
NCON VALUE		0	
INCOME VALUE			
PREVIOUS YEAR MKT VALUE		868,553	

PERMIT NUM	DESCRIPTION	AMT	ISSUED
B1908086	ADDITION	40,933	10/08/2019
19009057	CO ISSUED	0	08/22/2019
B1632024	NEW CONSTR	619,783	04/06/2016
MHA98068	MH MOVE-ON	0	08/01/1998

SALES DATA						
OFF RECORD Number	DATE	TYPE INST	Q U	V I	RSN CD	SALE PRICE
1974/0146	4/06/2015	WD	U	I	19	120,000
GRANTOR: POOLE H PRICE JR P/R						
GRANTEE: RYAN LIS T & HEIDI						
1718/0598	12/22/2010	QC	U	I	11	100
GRANTOR: WRIGHT JACK T SR						
GRANTEE: HICKEY KATHRYN J						

BUILDING NOTES												
----------------	--	--	--	--	--	--	--	--	--	--	--	--

BUILDING DIMENSIONS												
FSP=[YR=2019] W68 S10 BAS=[YR=2019] S33 E11 S10 FGR=[YR=2019] W11 S26 E23 N26 W12\$ E12 N2 STP=[YR=2019] E22 N6 STR=[YR=2019] E6 N8 W9 S6 FOP=[YR=2019] W19 S6 E20 N4 W1 N2\$ S2 E3\$ W2 S4 W20 S2\$ N8 E19 N6 E9 S6 E27 N16 W10 N17 W68\$ E68 N10\$ PTR= E15 FSP=[YR=2019] E53 S10 FUS=[YR=2019] S32 W17 STR=[YR=2019] S2 W9 N2 FST=[YR=2019] W5N5E5S5\$ N11 E9 S11\$ N11 W9 S6W5S5W22 N32 E53\$ W53 N10\$ W15\$.												

PT OF LOT 1 IN OR 1974/146
 (EX UTIL ESMT IN OR 720/622)
 LANDS OF EMIL O FRIEND S/D IN

RYAN LIS T/NICOL HEIDI S
 521 BONNIEVIEW RD
 FERNANDINA BEACH, FL 32034

2023

00-00-30-034B-0001-0010



BUILDING CHARACTERISTICS				
ELEMENT	CD			
Exterior Wall	25 MOD METAL 100			
Roof Structur	03 GABLE/HIP 100			
Roof Cover	12 MODULAR MT 100			
Interior Wall	01 MINIMUM 100			
Interior Floo	03 CONC FINSH 100			
Air Condition	01 NONE 100			
Heating Type	01 NONE 100			
Bedrooms	0 100			
Bathrooms	0 100			
Frame	05 STEEL 100			
Stories	1. 1. 100			
Units	0 100			
Quality	06 Quality Level 06			
DOR CODE	0100 SINGLE FAMILY			
MAP NUM	MKT AREA 02			
NEIGHBORHOOD/LOC	2020.00			
AREA TYPE	TOTAL GROSS AREA	PCT OF BASE	TOT ADJ AREA	SUBAREA MARKET VALUE
BAS	840	100	840	25,210
TOTALS	840		840	25,210

MARKET ADJUSTMENTS											
TYPE	MDL	EFF. AREA	TOT ADJ PTS	EFF. BASE RATE	REPL. COST NEW	AYB	EYB	ECON	FNCT	NORM	% COND
4											
GARAGE RES - 100% - 2020			Heated Area: 840			HX Base Yr 2020					
<div style="border: 1px solid black; width: 100%; height: 100%; display: flex; align-items: center; justify-content: center;"> <div style="border: 1px solid black; width: 80%; height: 80%; display: flex; align-items: center; justify-content: center;"> BAS 2019 </div> </div>											

NASSAU COUNTY PROPERTY		PAGE 2 of 2	8
VALUATION SUMMARY			
VALUATION BY		STANDARD	
VALUATION BY	Tax Group: 8	Tax Dist:	
BUILDING MARKET VALUE	672,128		
TOTAL MARKET OB/XF VALUE	12,126		
TOTAL LAND VALUE - MARKET	425,086		
TOTAL MARKET VALUE	1,109,340		
SOH/AGL Deduction	482,260		
ASSESSED VALUE	627,080		
TOTAL EXEMPTION VALUE	HX HB WX DX	60,000	
BASE TAXABLE VALUE	567,080		
TOTAL JUST VALUE	1,109,340		
NCON VALUE	0		
INCOME VALUE			
PREVIOUS YEAR MKT VALUE	868,553		
PERMIT NUM	DESCRIPTION	AMT	ISSUED

SALES DATA							
OFF RECORD Number	DATE	TYPE INST	Q / U	V / I	RSN CD	SALE PRICE	
1974/0146	4/06/2015	WD	U	I	19	120,000	
GRANTOR: POOLE H PRICE JR P/R							
GRANTEE: RYAN LIS T & HEIDI							
1718/0598	12/22/2010	QC	U	I	11	100	
GRANTOR: WRIGHT JACK T SR							
GRANTEE: HICKEY KATHRYN J							

EXTRA FEATURES															BLD DATE			LGL DATE		
L N	OB/XF CODE	DESCRIPTION	BLD CAP	L	W	UNITS	UT	Adj R	ADJ UNIT PRICE	ORIG COND	YEAR ON	YEAR ACTUAL	Q	% COND	OB/XF MKT VALUE	NOTES	XF DATE	LAND DATE	AG DATE	
															521 BONNIEVIEW RD, FERNANDINA BEACH					
															INC DATE					
															BLD DATE					
															XF DATE					
															INC DATE					
															LGL DATE					
															LAND DATE					
															AG DATE					

BUILDING NOTES														

BUILDING DIMENSIONS														
BAS=[YR=2019] W35 S24 E35 N24\$.														

LAND DESCRIPTION															TOTAL OB/XF									
L N	USE CODE	CLS	LAND USE DESCRIPTION	CAP	R D	LOC ZONE	FRONT	DEPTH	TOT LND UTS	UNIT TYPE	D T	DPTH FACT	% COND	TOT ADJ	UNIT PRICE	ADJ UNIT PRICE	LAND VALUE	OTHER ADJUSTMENTS AND NOTES	YEAR	DENSITY	DECL	FRZ	YR	CONSRV