

LOT 101
IN OR 1801/834
EGANS BLUFF EAST PB 5/367

O'ROARK NANCY F
2116 CIERA LN
FERNANDINA BEACH, FL 32034

2023

00-00-30-021E-0101-0000

BUILDING CHARACTERISTICS	
ELEMENT	CD CONSTRUCTION
Exterior Wall	10 ABOVE AVG 70
Exterior Wall	16 WD FR STUC 30
Roof Structure	03 GABLE/HIP 100
Roof Cover	03 COMP SHNGL 100
Interior Wall	05 DRYWALL 90
Interior Wall	08 DECORATIVE 10
Interior Floor	14 CARPET 80
Interior Floor	11 CLAY TILE 20
Air Condition	03 CENTRAL 100
Heating Type	04 AIR DUCTED 100
Bedrooms	4 100
Bathrooms	2 100
Frame	02 WOOD FRAME 100
Stories	1. 1. 100
Units	0 100
Occupancy	00 NONE 100

MARKET ADJUSTMENTS												
TYPE	MDL	EFF. AREA	TOT ADJ PTS	EFF. BASE RATE	REPL. COST NEW	AYB	EYB	ECON	FNCT	NORM	% COND	
0100	01	2,454	110.9808	100.16	245,793	1995	1999	0	0	0	11.15	88.85

NASSAU COUNTY PROPERTY			
VALUATION SUMMARY			PAGE 1 of 1
VALUATION BY		STANDARD	
Tax Group: 8		Tax Dist:	
BUILDING MARKET VALUE		218,387	
TOTAL MARKET OB/XF VALUE		6,319	
TOTAL LAND VALUE - MARKET		180,000	
TOTAL MARKET VALUE		404,706	
SOH/AGL Deduction		139,956	
ASSESSED VALUE		264,750	
TOTAL EXEMPTION VALUE		HX HB 50,000	
BASE TAXABLE VALUE		214,750	
TOTAL JUST VALUE		404,706	
NCON VALUE		0	
INCOME VALUE			
PREVIOUS YEAR MKT VALUE		379,829	

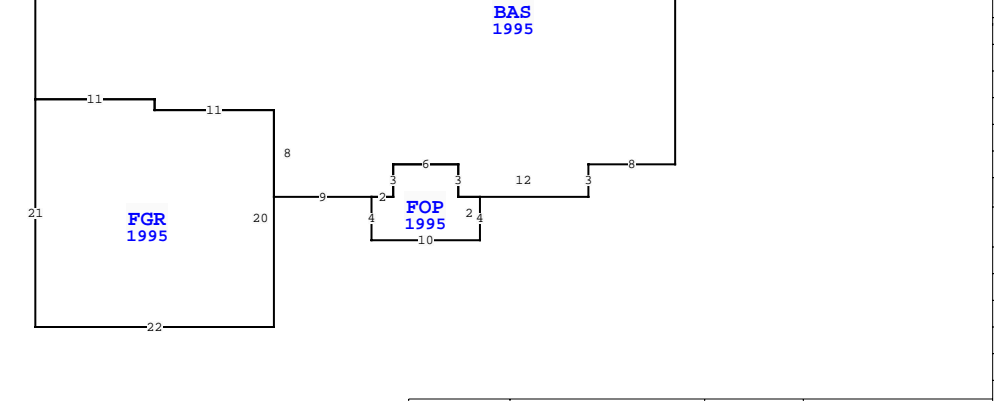

Quality	04 Quality Level 04			
DOR CODE	0100 SINGLE FAMILY			
MAP NUM	MKT AREA 02			
NEIGHBORHOOD/LOC	2026.00			
AREA TYPE	TOTAL GROSS AREA	PCT OF BASE	TOT ADJ AREA	SUBAREA MARKET VALUE
BAS	2,060	100	2,060	183,324
FGR	451	55	248	22,070
FOP	58	30	17	1,513
FOP	235	30	70	6,229
USP	196	30	59	5,250
TOTALS	3,000		2,454	218,387

PERMIT NUM	DESCRIPTION	AMT	ISSUED
B1213122	REPAIR/RRF	9,800	09/03/2012
B9501864	NEW CONSTR	150,000	04/01/1995

SALES DATA						
OFF RECORD Number	DATE	TYPE INST	Q / U	V / I	RSN CD	SALE PRICE
1801/0834	6/18/2012	WD Q	Q	I	02	196,000

GRANTOR: FEDERAL NATIONAL MORT
GRANTEE: O'ROARK NANCY F
1784/0718 3/12/2012 QC U I 11 100
GRANTOR: BANK OF AMERICA NATIO
GRANTEE: FEDERAL NATIONAL MI

EXTRA FEATURES																
L N	OB/XF CODE	DESCRIPTION	BLD CAP	L	W	UNITS	UT	Adj R	ADJ UNIT PRICE	ORIG COND	YEAR ON	YEAR ACTUAL	Q	% COND	OB/XF MKT VALUE	NOTES
1	0500	FP-PRE FAB	0	100	0	1.00	UT	3,500.00	3,500.00	100	1995	1995	3	79	2,765	
2	0811	CONCRETE B	0	100	53	16	SF	5.20	5.20	100	1995	1995	3	72	3,175	
3	0810	CONCRETE A	0	100	27	3	SF	6.50	6.50	100	1995	1995	3	72	379	

2116 CIERA LN, FERNANDINA BEACH										BLD DATE	03/03/2023	NW	LGL DATE	
										XF DATE			LAND DATE	
										INC DATE			AG DATE	

BUILDING NOTES												
----------------	--	--	--	--	--	--	--	--	--	--	--	--

BUILDING DIMENSIONS												
BAS=[YR=1995] W15 USP=[YR=1995] W28 S7 FOP=[YR=1995] S6 W1 S2 E2 S1 E2 N2 E9 S2 E16 N9 W28 \$ E28 N7 \$ S16 W16 N2 W9 S2 W2 N1 W2 N2 E1 N6 W16 S32 FGR=[YR=1995] S21 E22 N20 W11 N1 W11 \$ E11 S1 E11 S8 E9 FOP=[YR=1995] S4 E10 N4 W2 N3 W6 S3 W2 \$ E2 N3 E6 S3 E12 N3 E8 N45 \$.												

LAND DESCRIPTION													TOTAL OB/XF												
L N	USE CODE	CLS	LAND USE DESCRIPTION	CAP	R D	LOC ZONE	FRONT	DEPTH	TOT LND UTS	UNIT TYPE	D T	DPHT FACT	% COND	TOT ADJ	UNIT PRICE	ADJ UNIT PRICE	LAND VALUE	OTHER ADJUSTMENTS AND NOTES	YEAR	DENSITY	DECL	FRZ	YR	CONSRV	
1	000100	C	SFR	100	0003	RS-2	0.00	0.00	1.00	LT		1.00	1.00	1.00	180,000.00	180,000.00	180,000								