

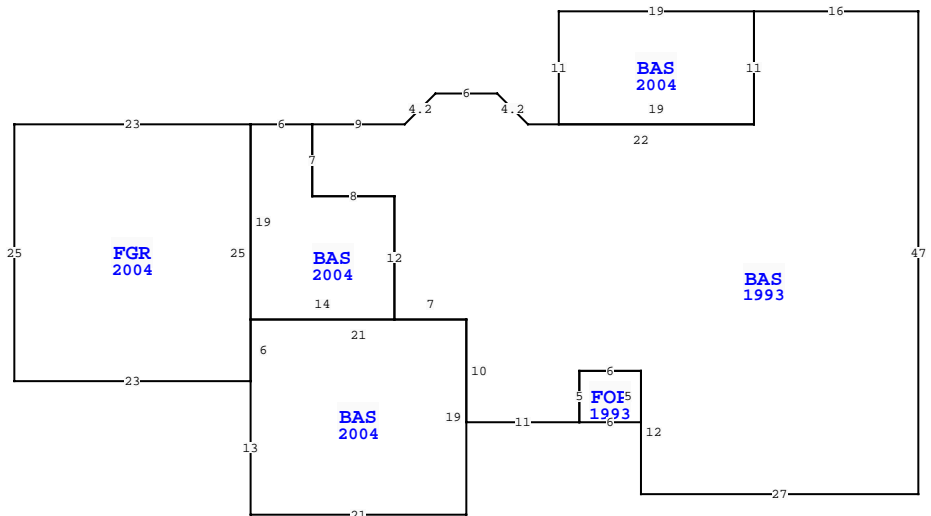

BUILDING CHARACTERISTICS		CONSTRUCTION	
ELEMENT	CD		
Exterior Wall	05	AVERAGE 70	
Exterior Wall	20	FACE BRICK 30	
Roof Structure	03	GABLE/HIP 100	
Roof Cover	03	COMP SHNGL 100	
Interior Wall	05	DRYWALL 100	
Interior Floor	14	CARPET 70	
Interior Floor	11	CLAY TILE 30	
Air Condition	03	CENTRAL 100	
Heating Type	04	AIR DUCTED 100	
Bedrooms		4 100	
Bathrooms		3 100	
Frame	02	WOOD FRAME 100	
Stories	1.	1. 100	
Units		0 100	
Occupancy	00	NONE 100	
Quality	06	Quality Level 06	
DOR CODE	0100	SINGLE FAMILY	
MAP NUM		MKT AREA	02
NEIGHBORHOOD/LOC	2031.00		
AREA TYPE	TOTAL GROSS AREA	PCT OF BASE	TOT ADJ AREA
BAS	1,827	100	1,827
BAS	209	100	209
BAS	210	100	210
BAS	399	100	399
FGR	575	55	316
FOP	30	30	9
TOTALS	3,250		2,970
			382,589

MARKET ADJUSTMENTS											
TYPE	MDL	EFF. AREA	TOT ADJ PTS	EFF. BASE RATE	REPL. COST NEW	AYB	EYB	ECON	FNCT	NORM	% COND
0900	01	2,970	119.7748	142.23	422,423	1989	2005	0	0	0	9.43
1 SNGL FAM - 100% - 2020 Heated Area: 2645 HX Base Yr 2020											



NASSAU COUNTY PROPERTY		PAGE 1 of 1	8
VALUATION SUMMARY			
VALUATION BY			STANDARD
Tax Group: 8		Tax Dist:	
BUILDING MARKET VALUE			382,589
TOTAL MARKET OB/XF VALUE			11,373
TOTAL LAND VALUE - MARKET			180,000
TOTAL MARKET VALUE			573,962
SOH/AGL Deduction			168,002
ASSESSED VALUE			405,960
TOTAL EXEMPTION VALUE	HX HB		50,000
BASE TAXABLE VALUE			355,960
TOTAL JUST VALUE			573,962
NCON VALUE			0
INCOME VALUE			
PREVIOUS YEAR MKT VALUE			551,704

PERMIT NUM	DESCRIPTION	AMT	ISSUED
22004592	SWIM POOL	72,000	03/24/2022
17001356	REMODEL	7,372	02/21/2017
17001215	REMODEL	5,000	02/16/2017
R035541	REPAIR/RRF	2,200	10/01/2003
5881	NEW CONSTR	66,290	07/20/1989

SALES DATA						
OFF RECORD Number	DATE	TYPE INST	Q / U	V / I	RSN CD	SALE PRICE
2453/1565	4/12/2021	WD	U	I	11	100
GRANTOR: HALLER JAMES M & ANN						
GRANTEE: HALLER FAMILY TRUST						
2313/0415	10/16/2019	WD	Q	I	01	529,000
GRANTOR: DIMARTINO MARK ANTHON						
GRANTEE: HALLER JAMES M & ANN						

EXTRA FEATURES																
L N	OB/XF CODE	DESCRIPTION	BLD CAP	L	W	UNITS	UT	Adj R	ADJ UNIT PRICE	ORIG COND	YEAR ON	YEAR ACTUAL	Q	% COND	OB/XF MKT VALUE	NOTES
1	0811	CONCRETE B	0 100	0	0	964.00	SF	5.20	5.20	100	1989	1989	3	59.5	2,983	
2	0500	FP-PRE FAB	0 100	0	0	1.00	UT	3,500.00	3,500.00	100	1989	1989	3	68	2,380	
3	0810	CONCRETE A	0 100	41	3	123.00	SF	6.50	6.50	100	1989	1989	3	59.5	476	
4	0810	CONCRETE A	0 100	4	4	16.00	SF	6.50	6.50	100	1989	1989	3	59.5	62	
5	0858	SCULP CONC	0 100	0	0	324.00	SF	13.00	13.00	100	2004	2004	3	96	4,044	
6	0810	CONCRETE A	0 100	5	3	15.00	SF	6.50	6.50	100	2004	2004	3	86	84	
7	0810	CONCRETE A	0 100	5	4	20.00	SF	6.50	6.50	100	2004	2004	3	86	112	
8	0940	SHEDS/PORT	0 100	14	10	140.00	SF	30.00	30.00	100	2004	2004	3	24	1,008	
9	0680	POLE SHED	0 100	14	4	56.00	SF	10.00	10.00	100	2004	2004	3	40	224	
TOTALS															11,373	

LAND DESCRIPTION																								
L N	USE CODE	CLS	LAND USE DESCRIPTION	CAP	R D	LOC ZONE	FRONT	DEPTH	TOT LND UTS	UNIT TYPE	D T	DPH FACT	% COND	TOT ADJ	UNIT PRICE	ADJ UNIT PRICE	LAND VALUE	OTHER ADJUSTMENTS AND NOTES	YEAR	DENSITY	DECL	FRZ	YR	CONSRV
1	000100	C	SFR	100		RS-2	0.00	0.00	1.00	LT		1.00	1.00	1.00	180,000.00	180,000.00	180,000							

BUILDING NOTES														
3109 EGANS BLUFF RD, FERNANDINA BEACH														
BLD DATE														
XF DATE														
INC DATE														
LGL DATE														
LAND DATE														
AG DATE														
BUILDING DIMENSIONS														
BAS=[YR=1993] W16 BAS=[YR=2004] W19 S11 E19 N11 \$ S11 W22 U3 L3 W6 D3 L3 W9 BAS=[YR=2004] W6 FGR=[YR=2004] W23 S25 E23 BAS=[YR=2004] S13 E21 N19 W21 S6 \$ N25 \$ S19 E14 N12 W8 N7 \$ S7 E8 S12 E7 S10 E11 FOP=[YR=1993] E6 N5 W6 S5 \$ N5 E6 S12 E27 N47 \$.														